

Lecture 12:

Self-Supervised Learning

Administrative

- Good job on finishing the midterm :)
- Assignment 3 will be out (due 5/28; submit code often and early)
- Projects milestone (due 5/19; no late days)
- Final Project Report (due 6/5; no late days)
- Poster session 6/12
- Please check Ed posts regarding the final project report and poster session logistics

Lots of Computer Vision Tasks

Classification



CAT

No spatial extent

Semantic Segmentation

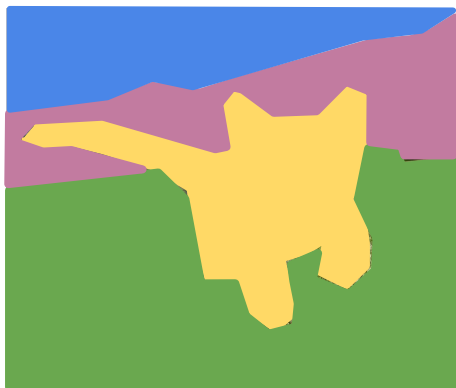

GRASS, CAT, TREE, SKY

No objects, just pixels

Object Detection

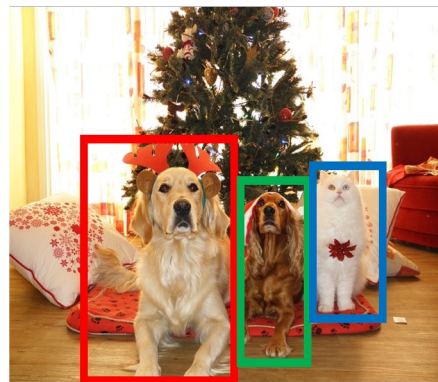

DOG, DOG, CAT

Multiple Object

Instance Segmentation



DOG, DOG, CAT

[This image is CC0 public domain](#)

Last Week: Visualizing and Understanding

schooner

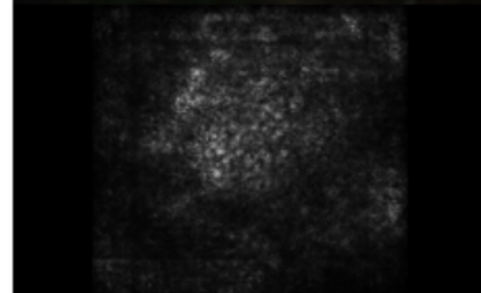
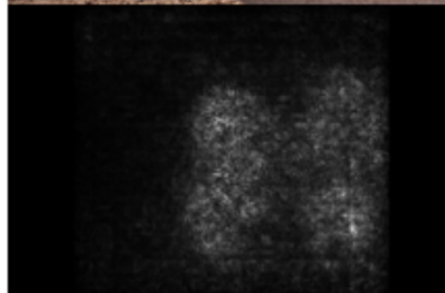
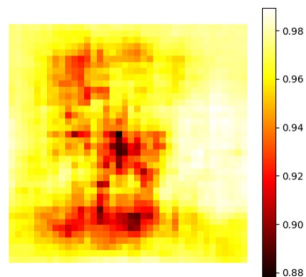

African elephant, *Loxodonta africana*

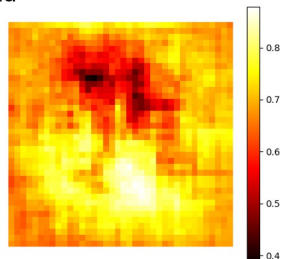
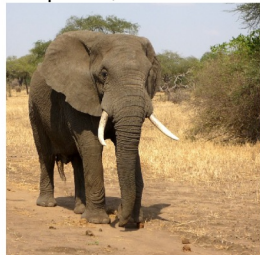

Last Week: Visualizing and Understanding

Test image L2 Nearest neighbors in feature space

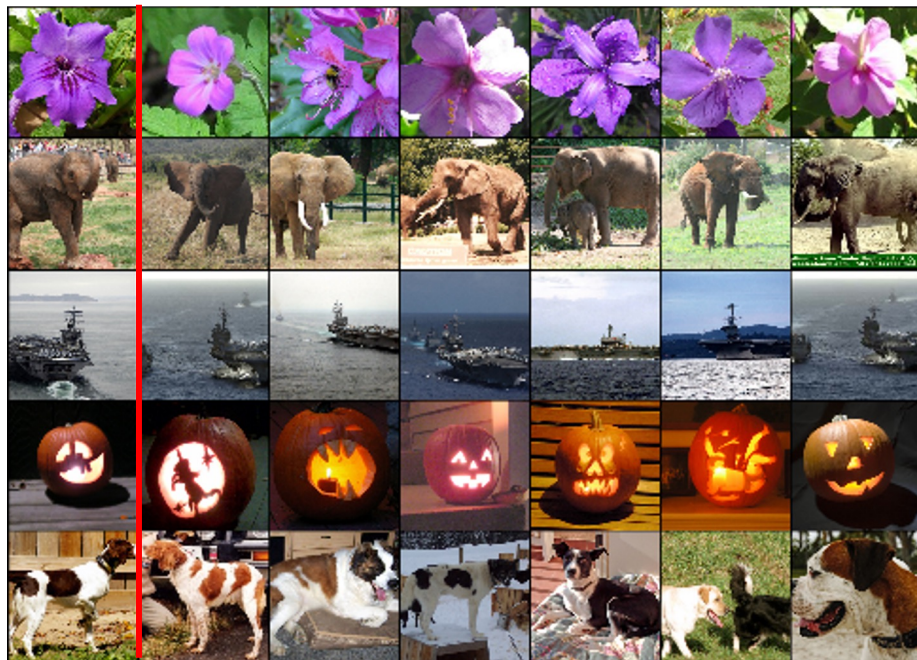

Recall: Nearest neighbors in pixel space



4096-dim vector

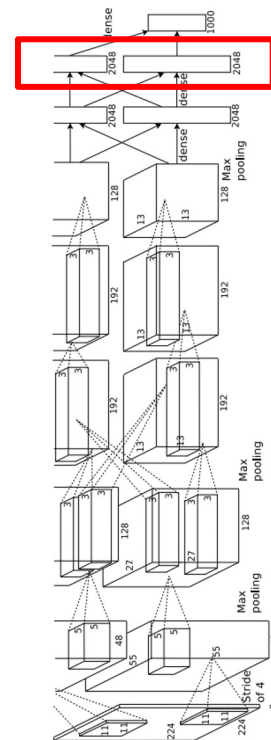

Krizhevsky et al, "ImageNet Classification with Deep Convolutional Neural Networks", NIPS 2012.
 Figures reproduced with permission.

Learned Representations

Test image L2 Nearest neighbors in feature space

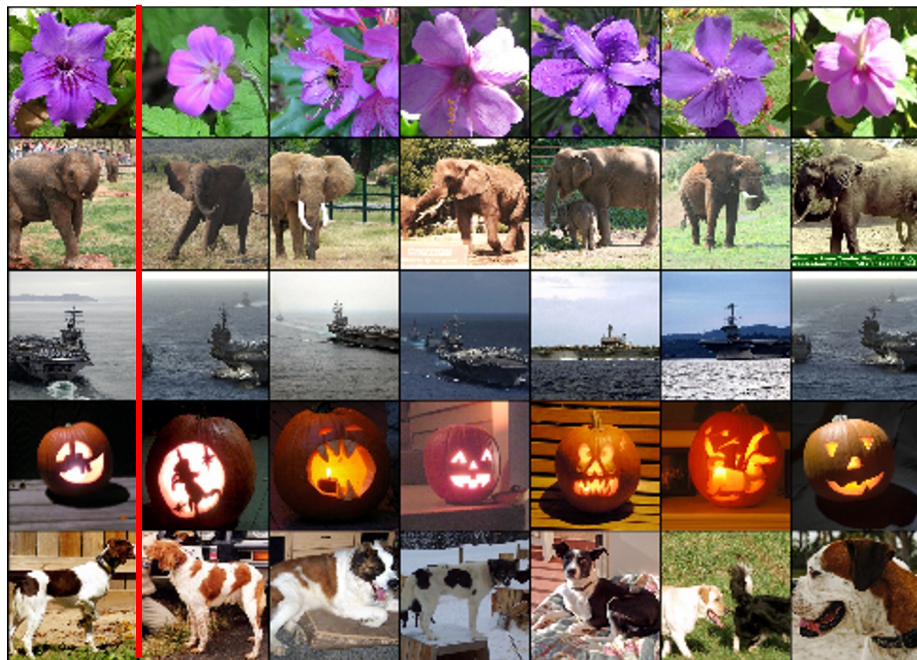

Recall: Nearest neighbors in pixel space



4096-dim vector

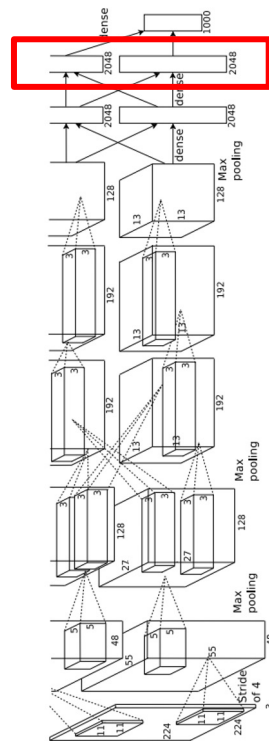

Krizhevsky et al, "ImageNet Classification with Deep Convolutional Neural Networks", NIPS 2012.
Figures reproduced with permission.

Learned Representations

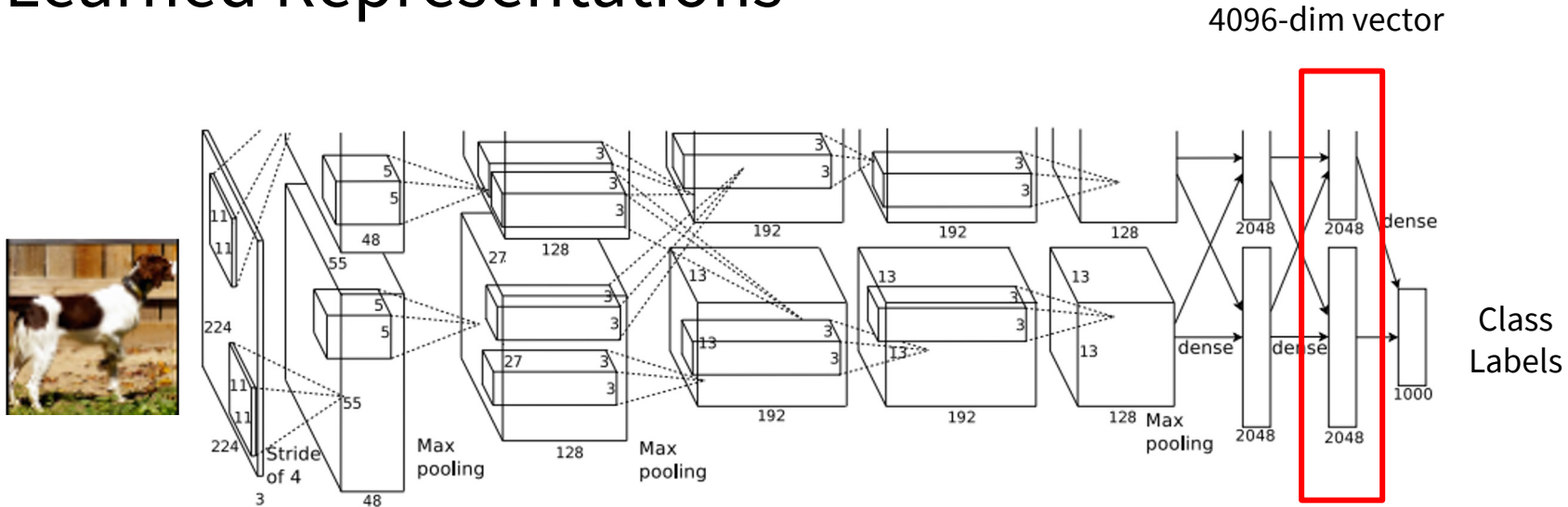

What is the problem with large-scale training?

- **We need a lot of labeled data**

Is there a way we can train neural networks without the need for huge manually labeled datasets?

Krizhevsky et al, "ImageNet Classification with Deep Convolutional Neural Networks", NIPS 2012.
Figures reproduced with permission.

Self-Supervised Learning

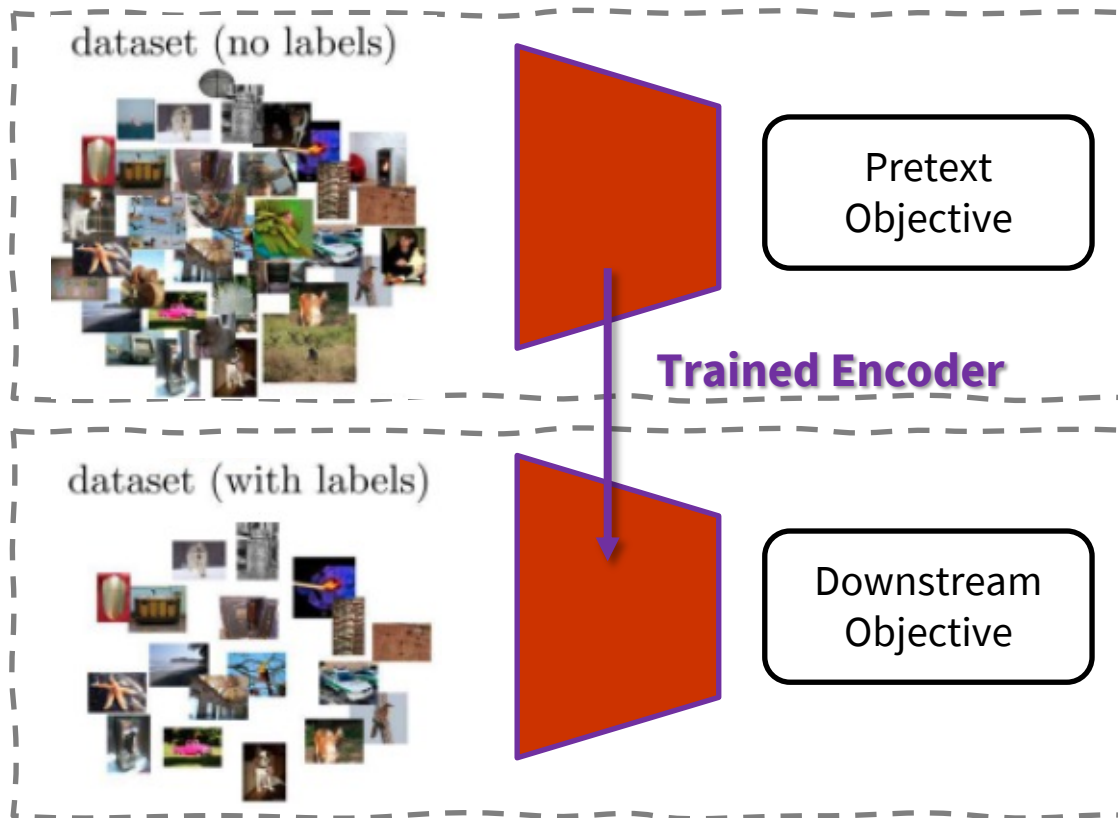

Pretext Task

- Define a task based on the data itself
- No manual annotation
- Could be considered an **unsupervised** task;
- but we learn with supervised learning objectives, e.g., classification or regression.

Downstream Task

- The application you care about
- You do not have large datasets
- The dataset is labeled

Self-Supervised Learning – Pretext Task

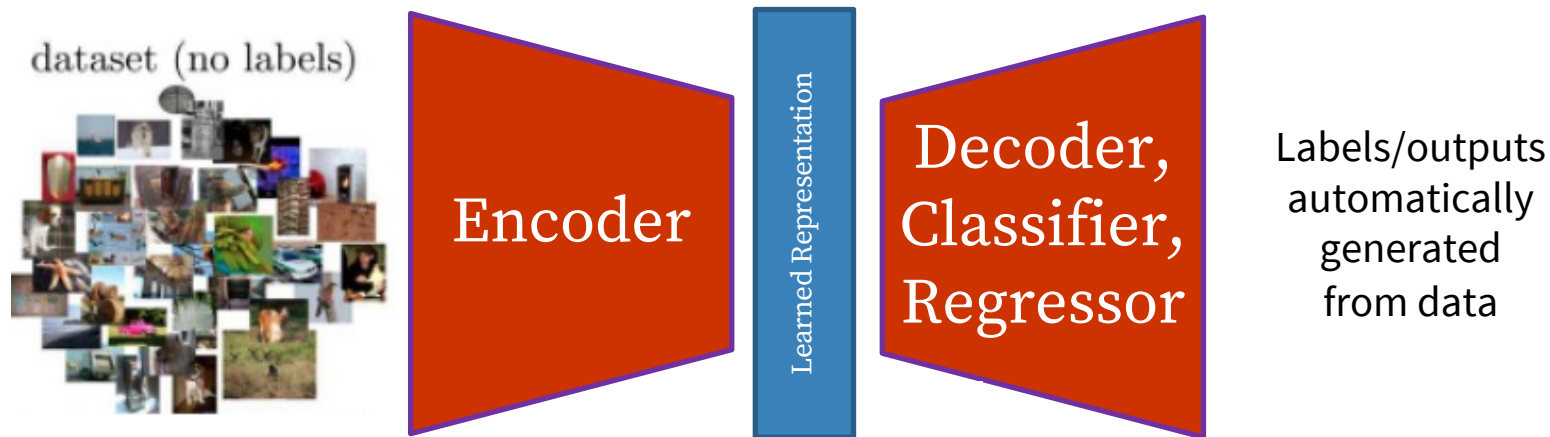

Self-Supervised Learning – Downstream Task

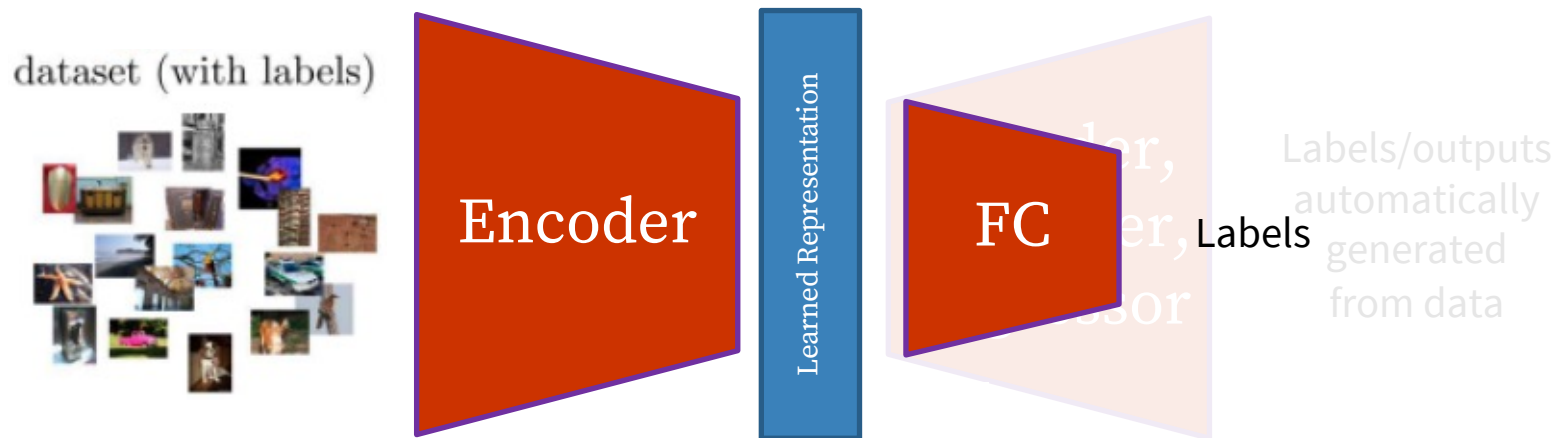

Self-supervised pretext tasks

Example: learn to predict image transformations / complete corrupted images

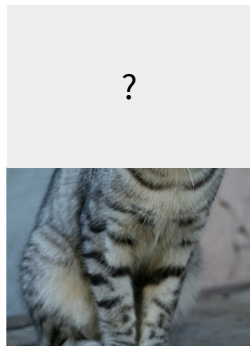
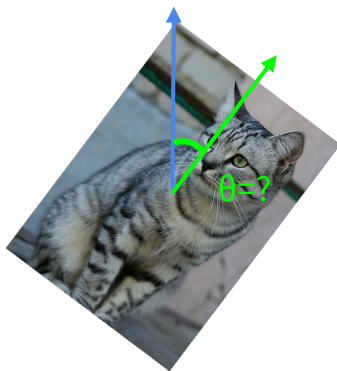
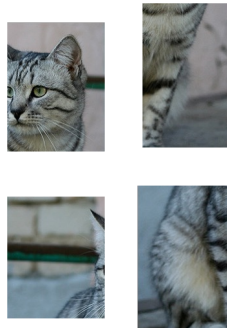

image completion



rotation prediction



“jigsaw puzzle”



colorization

1. Solving the pretext tasks allow the model to learn good features.
2. We can automatically generate labels for the pretext tasks.

How to evaluate a self-supervised learning method?

- **Pretext Task Performance**

- Measure how well the model performs on the task it was trained on without labels.

- **Representation Quality**

- Evaluate the quality of the learned representations
 - *Linear Evaluation Protocol*: Train a linear classifier on the learned representations;
 - *Clustering*: Measure clustering performance;
 - *t-SNE*: Visualize the representations to assess their separability.)

- **Robustness and Generalization**

- Test how well the model generalizes to different datasets and is robust to variations.

- **Computational Efficiency**

- Assess the efficiency of the method in terms of training time and resource requirements.

- **Transfer Learning and Downstream Task Performance**

- Assess the utility of the learned representations by transferring them to a downstream supervised task.

How to evaluate a self-supervised learning method?

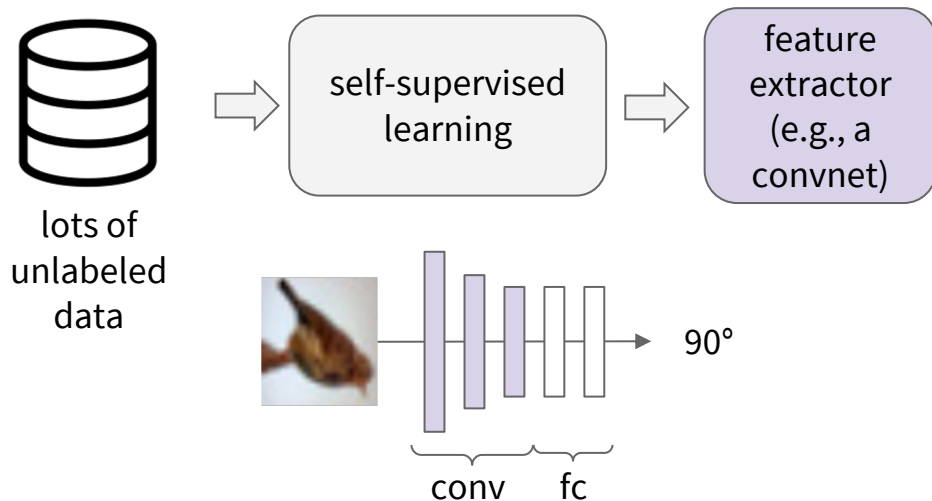

1. Learn good feature extractors from self-supervised pretext tasks, e.g., predicting image rotations

How to evaluate a self-supervised learning method?

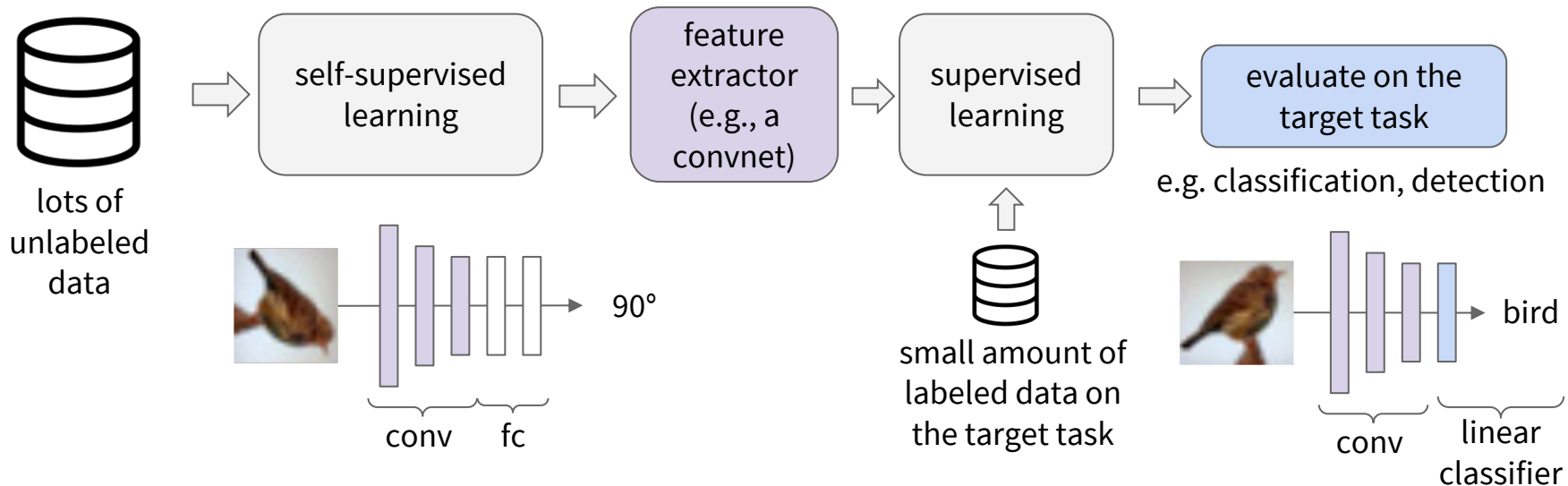

1. Learn good feature extractors from self-supervised pretext tasks, e.g., predicting image rotations

2. Attach a shallow network on the feature extractor; train the shallow network on the target task with small amount of labeled data

Broader picture

Today's lecture

computer vision

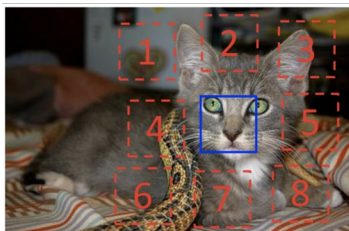

Doersch et al., 2015

robot / reinforcement learning



Dense Object Net (Florence and Manuelli et al., 2018)

language modeling

GPT-4 Technical Report

OpenAI*

Abstract

We report the development of GPT-4, a large-scale, multimodal model which can accept image and text inputs and produce text outputs. While less capable than humans in many real-world scenarios, GPT-4 exhibits human-level performance on various professional and academic benchmarks, including passing a simulated bar exam with a score around the top 10% of test takers. GPT-4 is a Transformer-based model pre-trained to predict the next token in a document. The post-training alignment process results in improved performance on measures of factuality and adherence to desired behavior. A core component of this project was developing infrastructure and optimization methods that behave predictably across a wide range of scales. This allowed us to accurately predict some aspects of GPT-4's performance based on models trained with no more than 1/1,000th the compute of GPT-4.

GPT-4 (OpenAI 2023)

speech synthesis

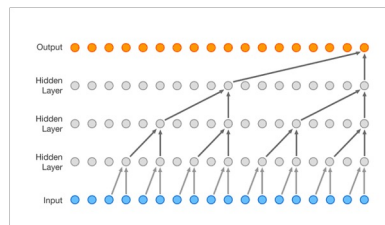

Wavenet (van den Oord et al., 2016)

...

Today's Agenda

Pretext tasks from image transformations

- Rotation, inpainting, rearrangement, coloring

Contrastive representation learning

- Intuition and formulation
- Instance contrastive learning: SimCLR and MOCO
- Sequence contrastive learning: CPC

Today's Agenda

Pretext tasks from image transformations

- Rotation, inpainting, rearrangement, coloring

Contrastive representation learning

- Intuition and formulation
- Instance contrastive learning: SimCLR and MOCO
- Sequence contrastive learning: CPC

Pretext task: predict rotations



90° rotation

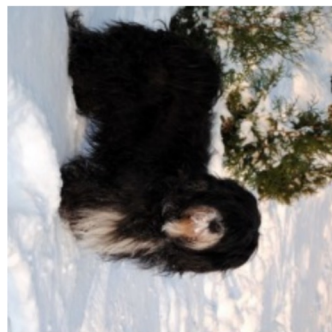

270° rotation

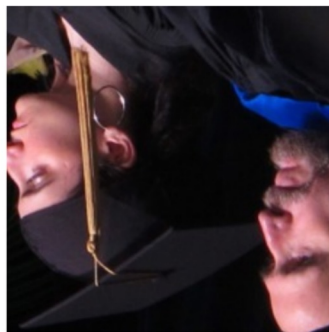

180° rotation



0° rotation

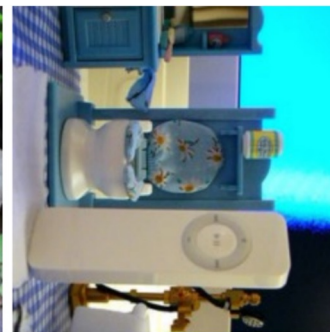

270° rotation

Hypothesis: a model could recognize the correct rotation of an object only if it has the “visual commonsense” of what the object should look like unperturbed.

(Image source: [Gidaris et al. 2018](#))

Pretext task: predict rotations

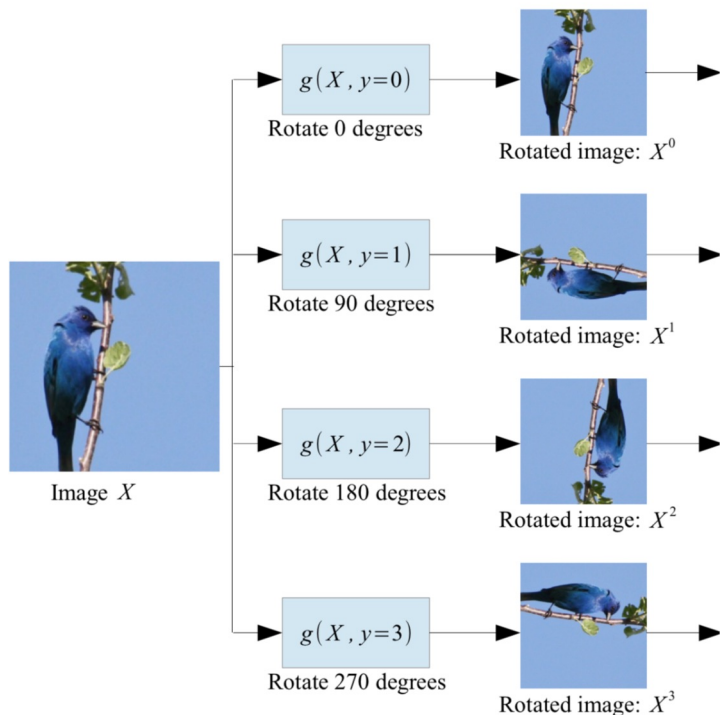

Self-supervised learning by rotating the entire input images.

The model learns to predict which rotation is applied (4-way classification)

(Image source: [Gidaris et al. 2018](#))

Pretext task: predict rotations

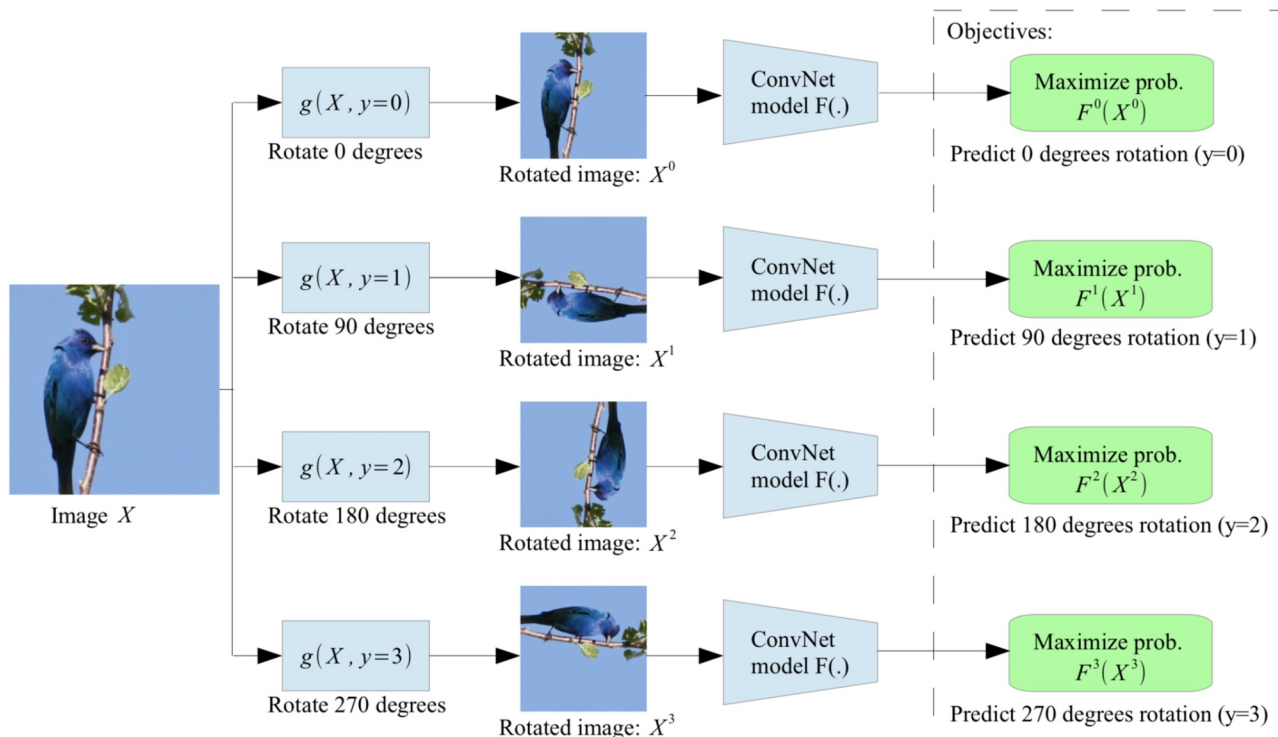

(Image source: [Gidaris et al. 2018](#))

Self-supervised learning by rotating the entire input images.

The model learns to predict which rotation is applied (4-way classification)

Evaluation on semi-supervised learning

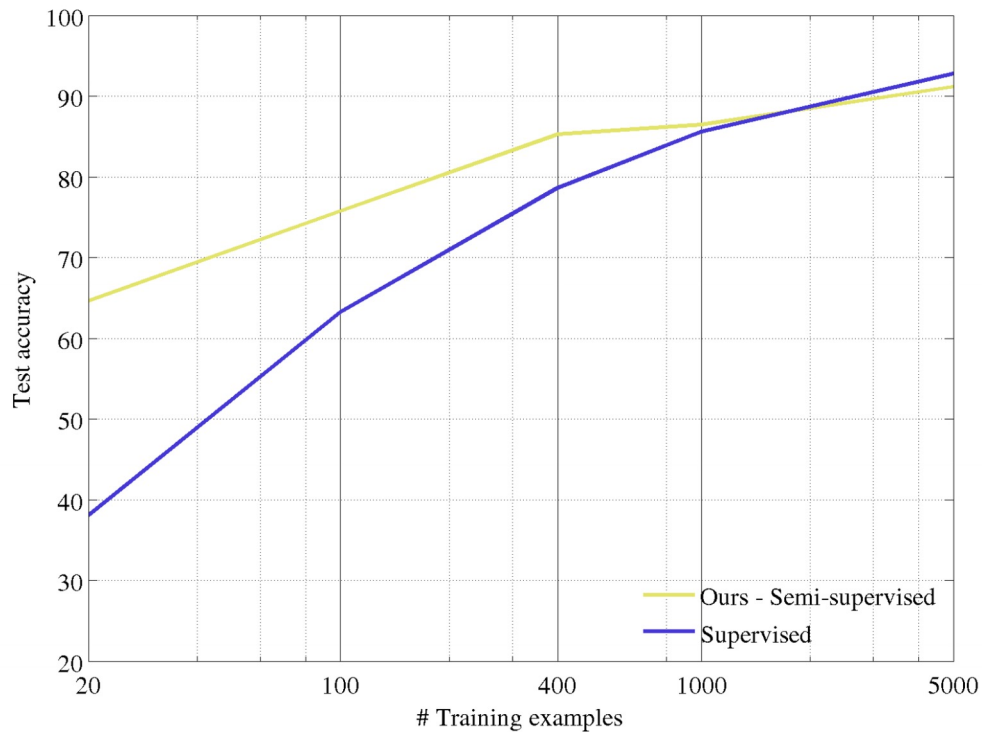

Self-supervised learning on CIFAR10 (entire training set).

Freeze conv1 + conv2
Learn conv3 + linear layers with subset of labeled CIFAR10 data (classification).

(Image source: [Gidaris et al. 2018](#))

Transfer learned features to supervised learning

Trained layers	Classification (%mAP)		Detection (%mAP)	Segmentation (%mIoU)
	fc6-8	all	all	all
ImageNet labels	78.9	79.9	56.8	48.0
Random		53.3	43.4	19.8
Random rescaled Krähenbühl et al. (2015)	39.2	56.6	45.6	32.6
Egomotion (Agrawal et al., 2015)	31.0	54.2	43.9	
Context Encoders (Pathak et al., 2016b)	34.6	56.5	44.5	29.7
Tracking (Wang & Gupta, 2015)	55.6	63.1	47.4	
Context (Doersch et al., 2015)	55.1	65.3	51.1	
Colorization (Zhang et al., 2016a)	61.5	65.6	46.9	35.6
BIGAN (Donahue et al., 2016)	52.3	60.1	46.9	34.9
Jigsaw Puzzles (Noroozi & Favaro, 2016)	-	67.6	53.2	37.6
NAT (Bojanowski & Joulin, 2017)	56.7	65.3	49.4	
Split-Brain (Zhang et al., 2016b)	63.0	67.1	46.7	36.0
ColorProxy (Larsson et al., 2017)		65.9		38.4
Counting (Noroozi et al., 2017)	-	67.7	51.4	36.6
(Ours) RotNet	70.87	72.97	54.4	39.1

Pretrained with full ImageNet supervision

No pretraining

Self-supervised learning on ImageNet (entire training set) with AlexNet.

Finetune on labeled data from Pascal VOC 2007.

Self-supervised learning with rotation prediction

source: [Gidaris et al. 2018](#)

Visualize learned visual attentions

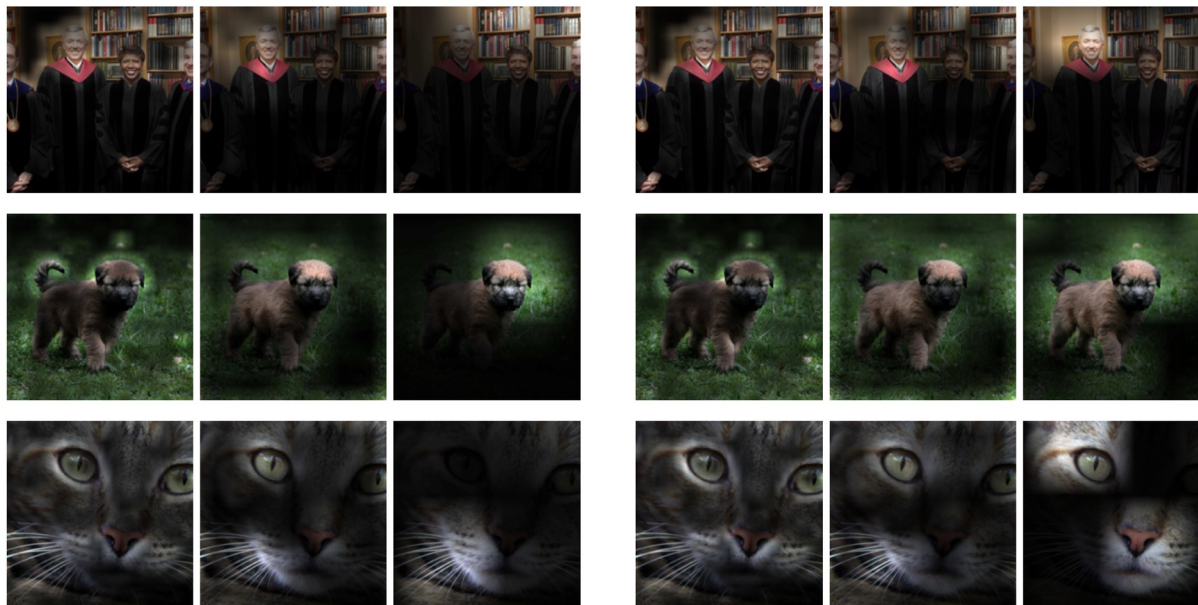

Conv1 27×27 Conv3 13×13 Conv5 6×6

(a) Attention maps of supervised model

Conv1 27×27 Conv3 13×13 Conv5 6×6

(b) Attention maps of our self-supervised model

(Image source: [Gidaris et al. 2018](#))

Pretext task: predict relative patch locations

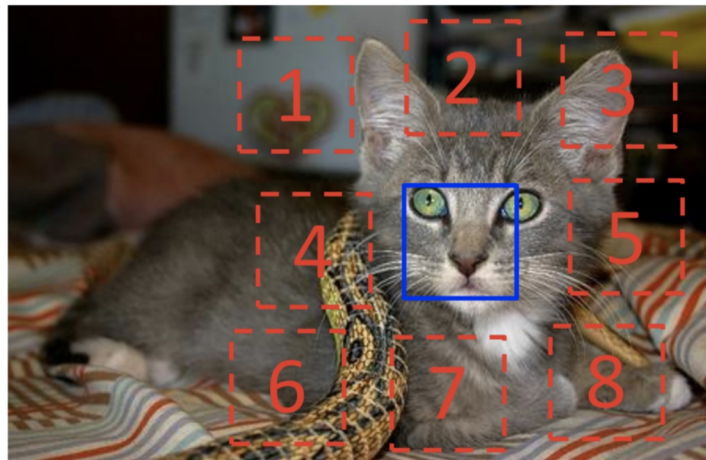

$$X = \left(\begin{array}{c} \text{[Kitten Face]} \\ \text{[Kitten Ear]} \end{array} \right); Y = 3$$

Example:

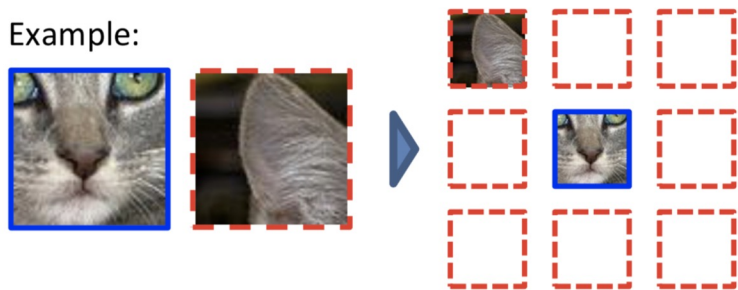

Question 1:



Question 2:



(Image source: [Doersch et al., 2015](#))

Pretext task: solving “jigsaw puzzles”

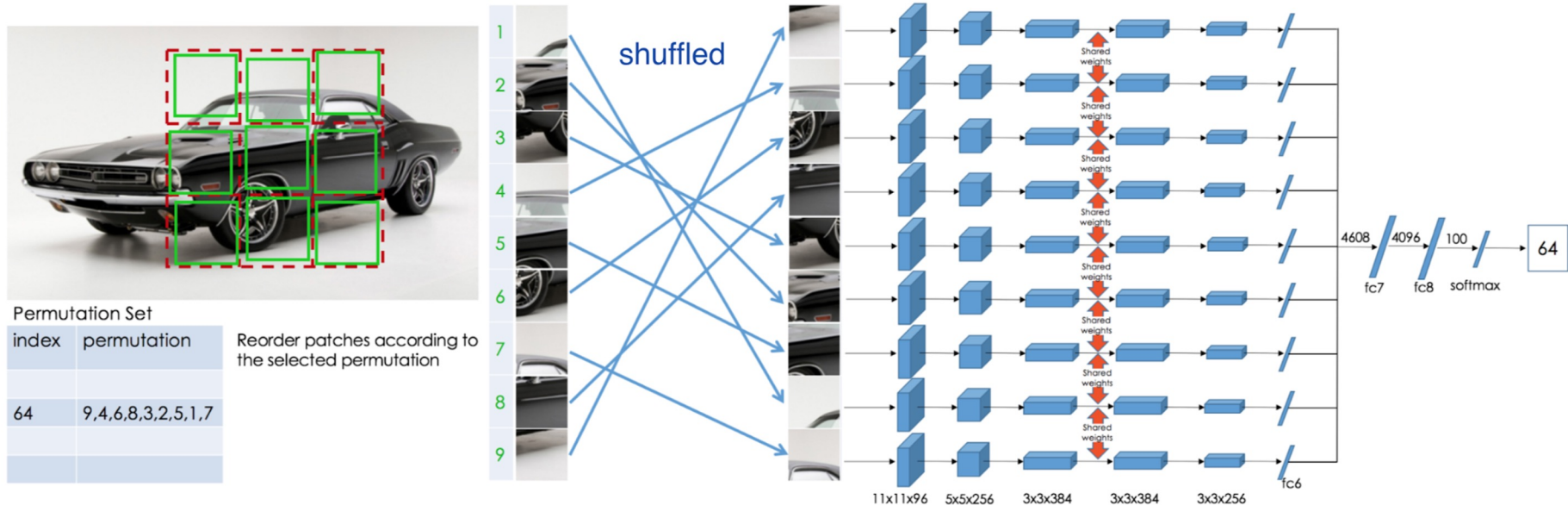

(Image source: [Noroozi & Favaro, 2016](#))

Transfer learned features to supervised learning

Table 1: Results on PASCAL VOC 2007 Detection and Classification. The results of the other methods are taken from Pathak *et al.* [30].

Method	Pretraining time	Supervision	Classification	Detection	Segmentation
Krizhevsky <i>et al.</i> [25]	3 days	1000 class labels	78.2%	56.8%	48.0%
Wang and Gupta[39]	1 week	motion	58.4%	44.0%	-
Doersch <i>et al.</i> [10]	4 weeks	context	55.3%	46.6%	-
Pathak <i>et al.</i> [30]	14 hours	context	56.5%	44.5%	29.7%
Ours	2.5 days	context	67.6%	53.2%	37.6%

“Ours” is feature learned from solving image Jigsaw puzzles (Noroozi & Favaro, 2016). Doersch et al. is the method with relative patch location

(source: [Noroozi & Favaro, 2016](#))

Pretext task: predict missing pixels (inpainting)

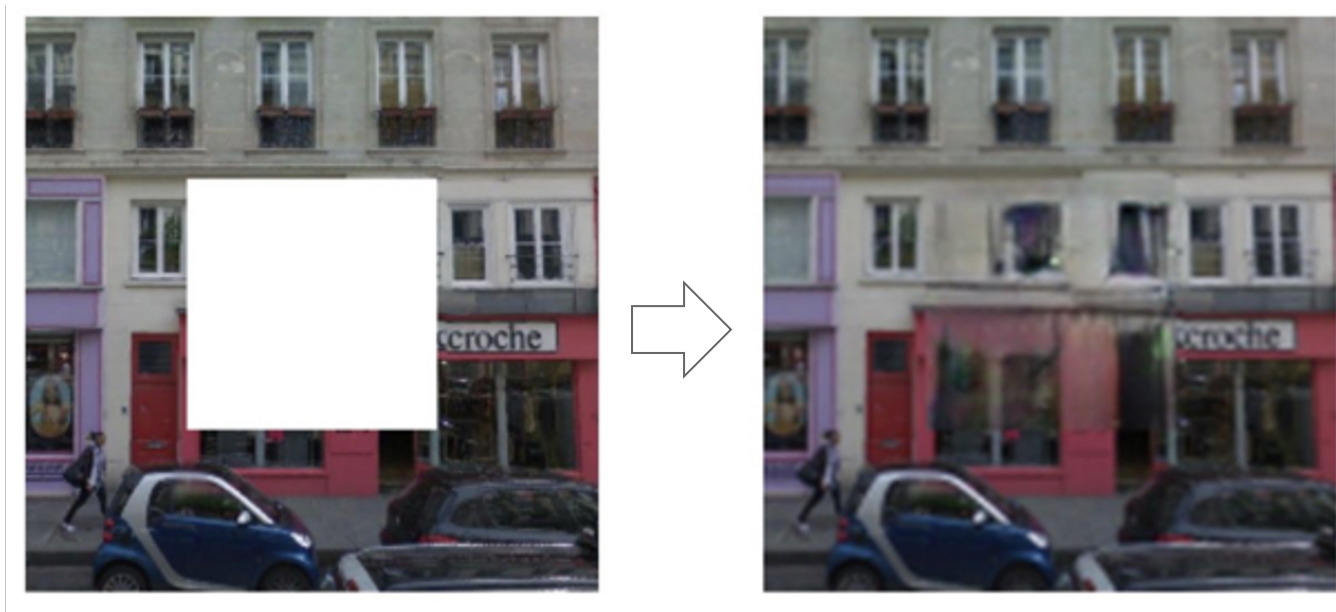

Context Encoders: Feature Learning by Inpainting (Pathak et al., 2016)

Source: [Pathak et al., 2016](#)

Learning to inpaint by reconstruction

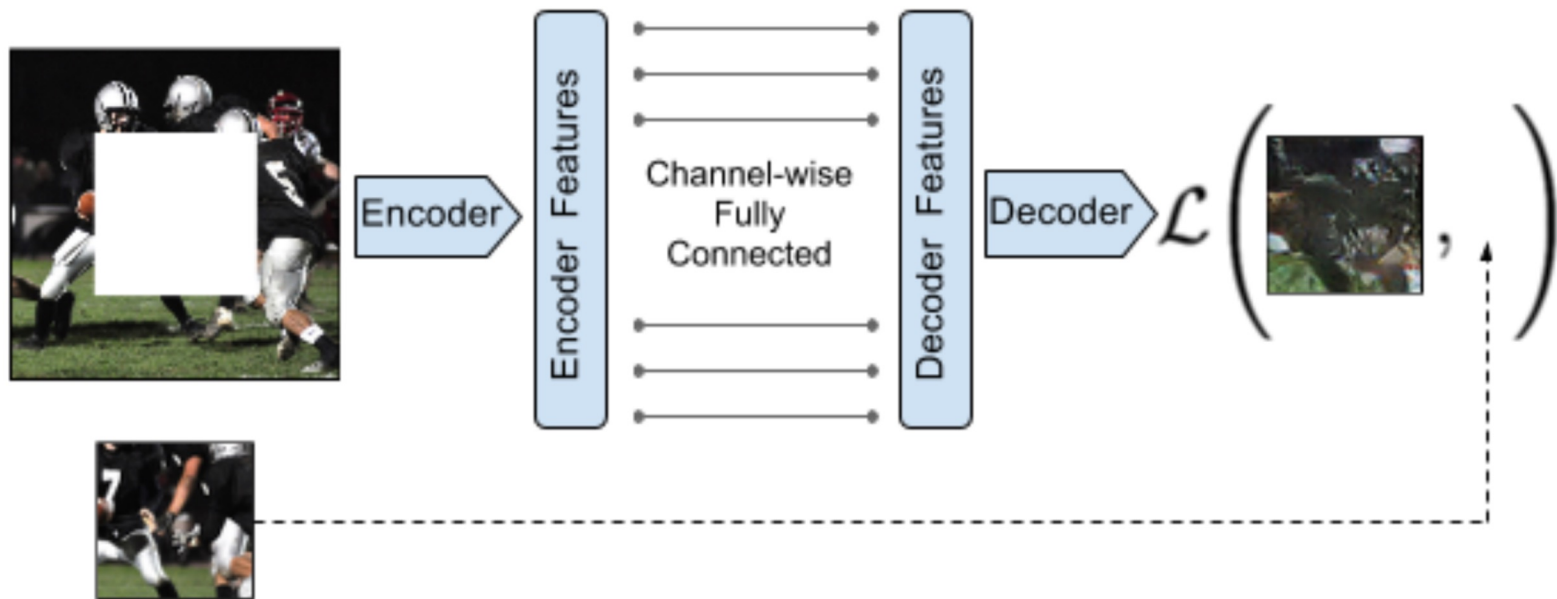

Learning to reconstruct the missing pixels

Source: [Pathak et al., 2016](#)

Inpainting evaluation



Input (context)

reconstruction

Source: [Pathak et al., 2016](#)

Learning to inpaint by reconstruction

(We will talk about adversarial learning in the next lecture)

Loss = reconstruction + adversarial learning

$$L(x) = L_{recon}(x) + L_{adv}(x)$$

$$L_{recon}(x) = ||M * (x - F_{\theta}((1 - M) * x))||_2^2$$

$$L_{adv} = \max_D \mathbb{E}[\log(D(x))] + \log(1 - D(F((1 - M) * x)))]$$

Adversarial loss between “real” images and inpainted images

Source: [Pathak et al., 2016](#)

Inpainting evaluation



Input (context)



reconstruction



adversarial



recon + adv

Source: [Pathak et al., 2016](#)

Transfer learned features to supervised learning

Pretraining Method	Supervision	Pretraining time	Classification	Detection	Segmentation
ImageNet [26]	1000 class labels	3 days	78.2%	56.8%	48.0%
Random Gaussian	initialization	< 1 minute	53.3%	43.4%	19.8%
Autoencoder	-	14 hours	53.8%	41.9%	25.2%
Agrawal <i>et al.</i> [1]	egomotion	10 hours	52.9%	41.8%	-
Wang <i>et al.</i> [39]	motion	1 week	58.7%	47.4%	-
Doersch <i>et al.</i> [7]	relative context	4 weeks	55.3%	46.6%	-
Ours	context	14 hours	56.5%	44.5%	30.0%

Self-supervised learning on ImageNet training set, transfer to classification (Pascal VOC 2007), detection (Pascal VOC 2007), and semantic segmentation (Pascal VOC 2012)

Source: [Pathak et al., 2016](#)

Pretext task: image coloring

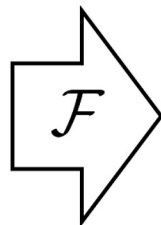
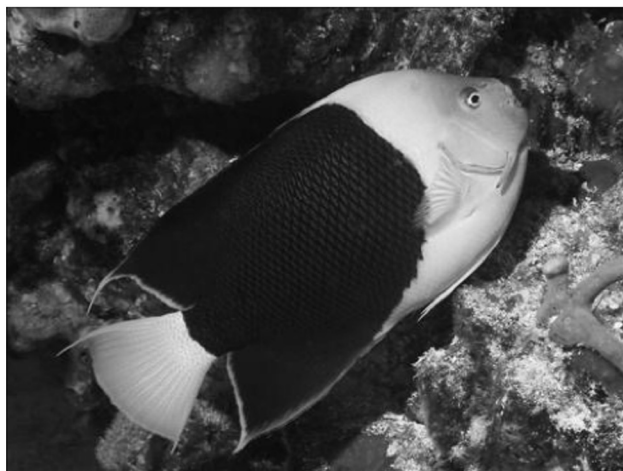

Grayscale image: L channel

$$\mathbf{X} \in \mathbb{R}^{H \times W \times 1}$$

Color information: ab channels

$$\hat{\mathbf{Y}} \in \mathbb{R}^{H \times W \times 2}$$

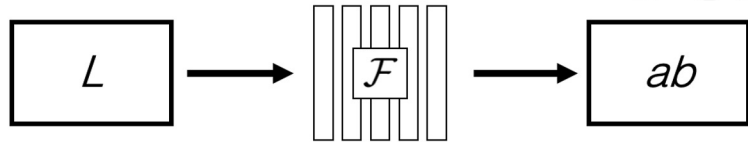

Source: Richard Zhang / Phillip Isola

Pretext task: image coloring

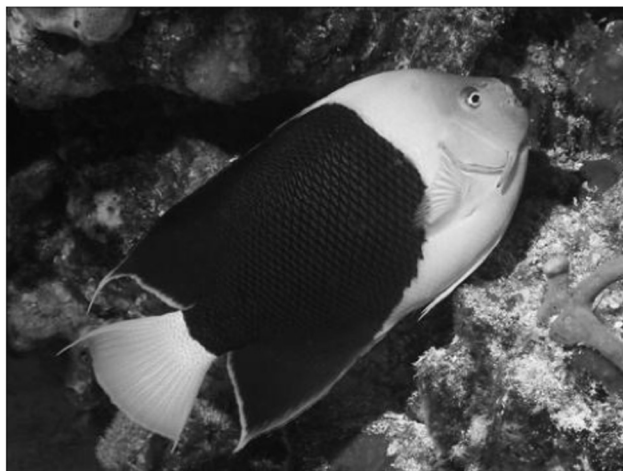

Grayscale image: L channel

$$\mathbf{X} \in \mathbb{R}^{H \times W \times 1}$$

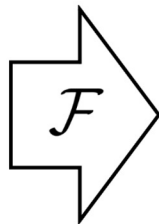

Concatenate (L, ab) channels

$$(\mathbf{X}, \hat{\mathbf{Y}})$$

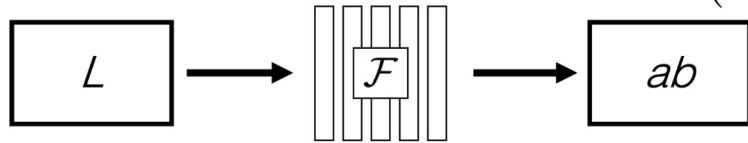

Source: Richard Zhang / Phillip Isola

Learning features from colorization: Split-brain Autoencoder

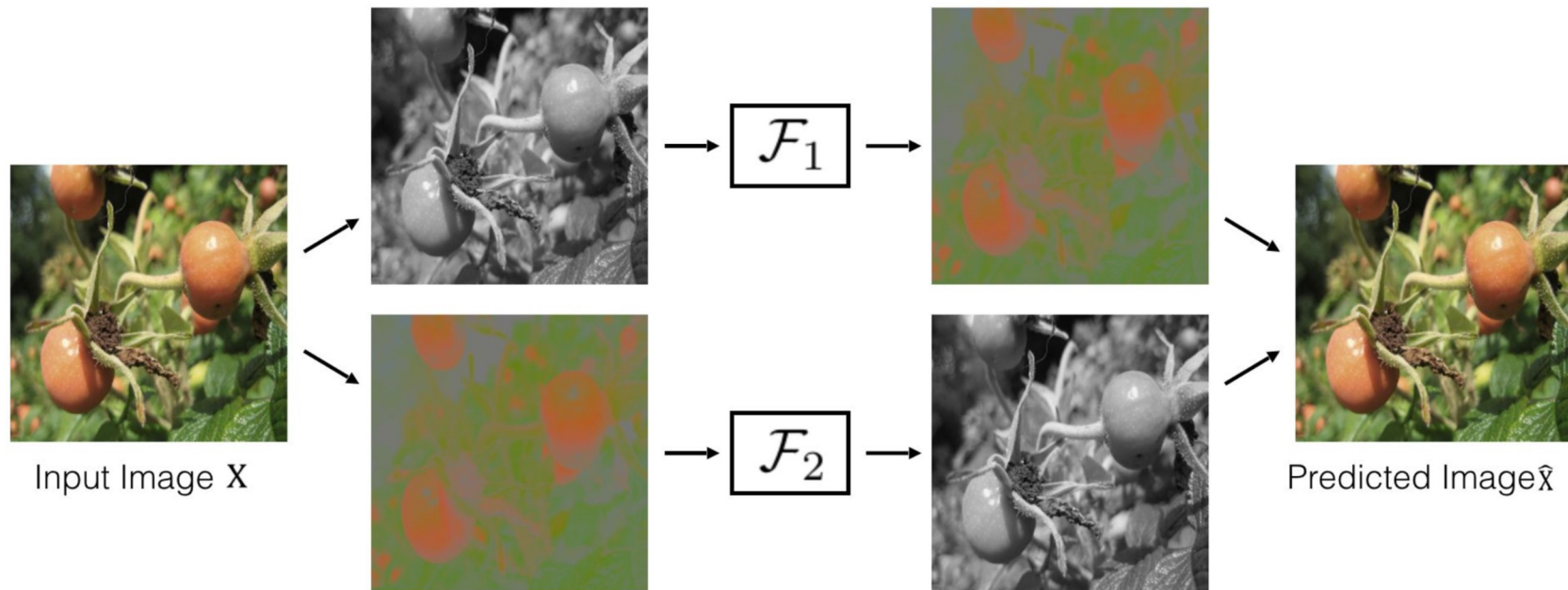

Source: Richard Zhang / Phillip Isola

Learning features from colorization: Split-brain Autoencoder

Idea: cross-channel predictions

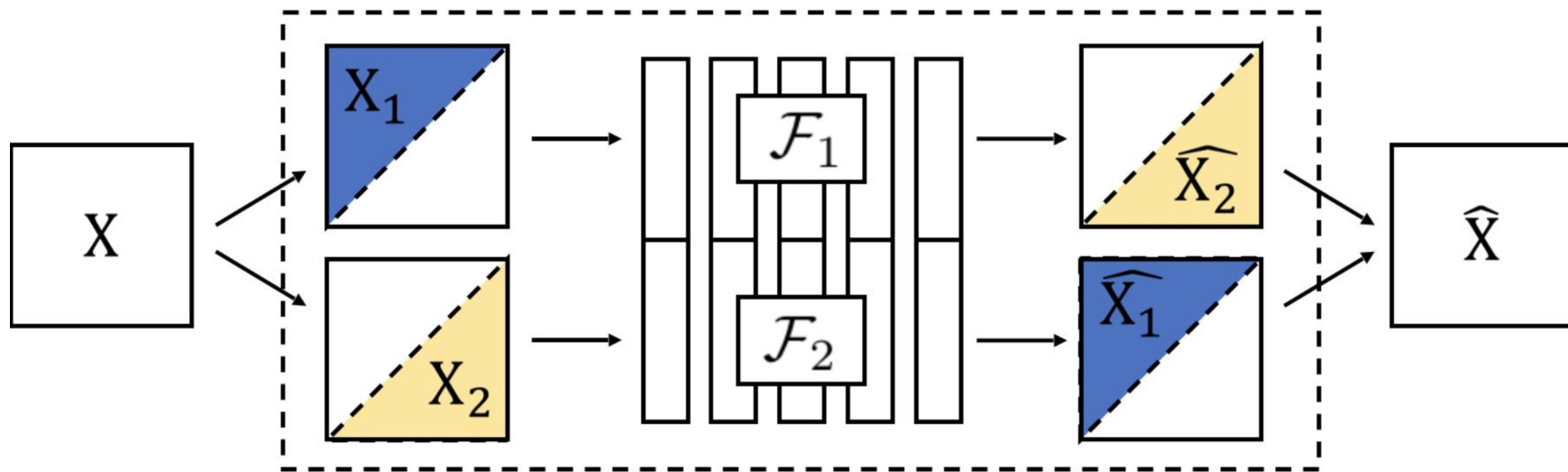

Split-Brain Autoencoder

Source: Richard Zhang / Phillip Isola

Learning features from colorization: Split-brain Autoencoder

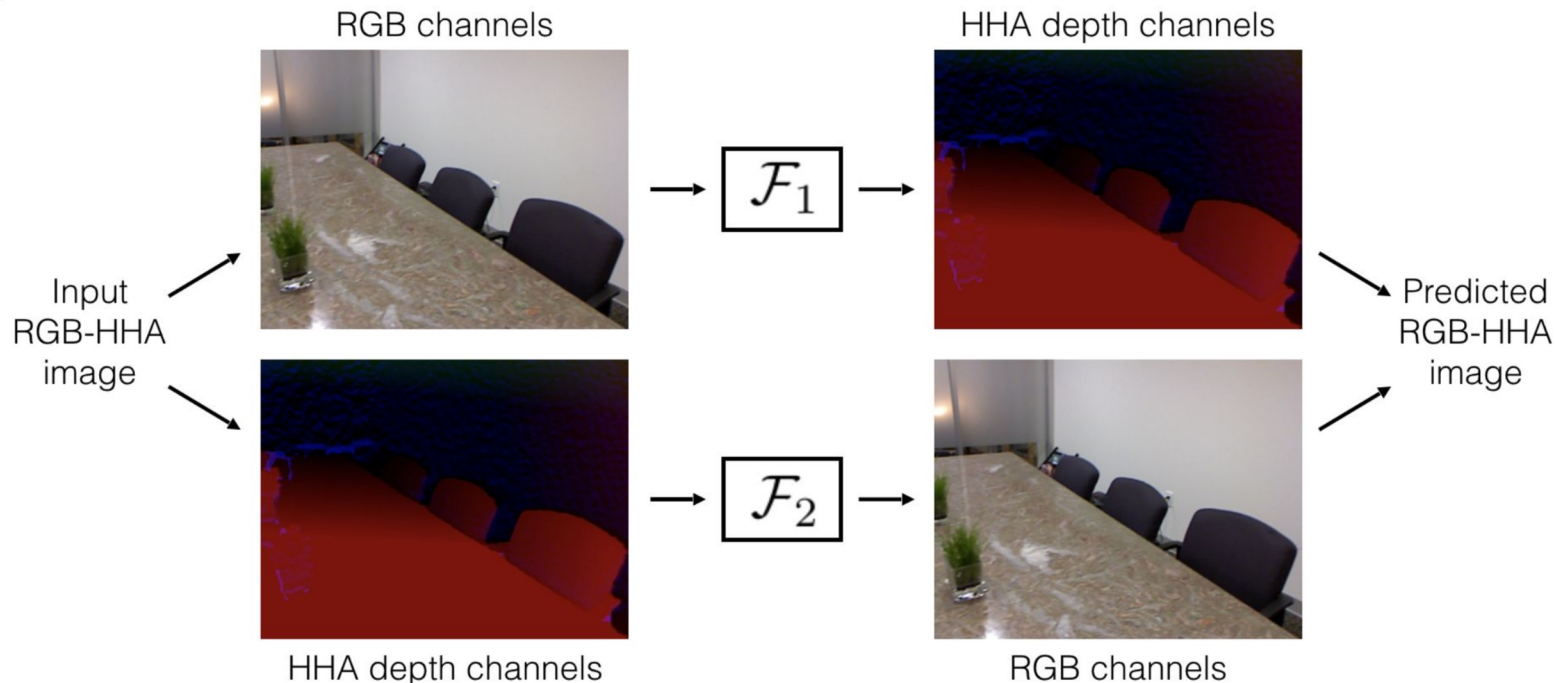

Source: Richard Zhang / Phillip Isola

Transfer learned features to supervised learning

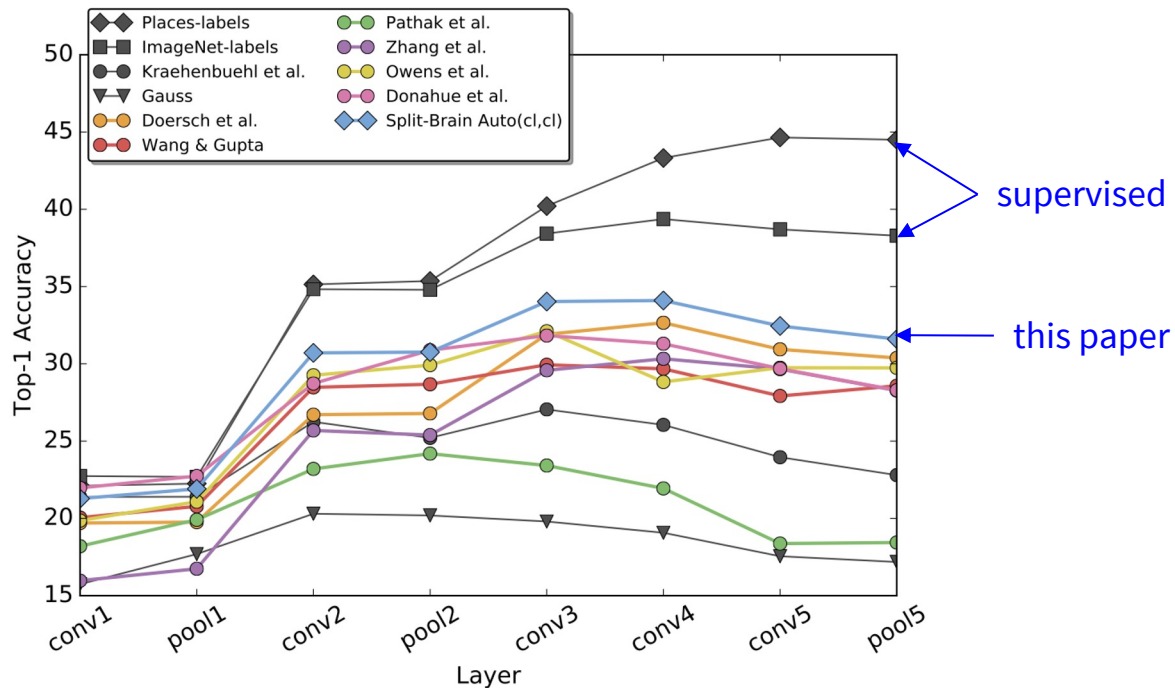

Self-supervised learning on ImageNet (entire training set).

Use concatenated features from F_1 and F_2

Labeled data is from the Places (Zhou 2016).

Source: [Zhang et al., 2017](#)

Pretext task: image coloring



Source: Richard Zhang / Phillip Isola

Pretext task: image coloring

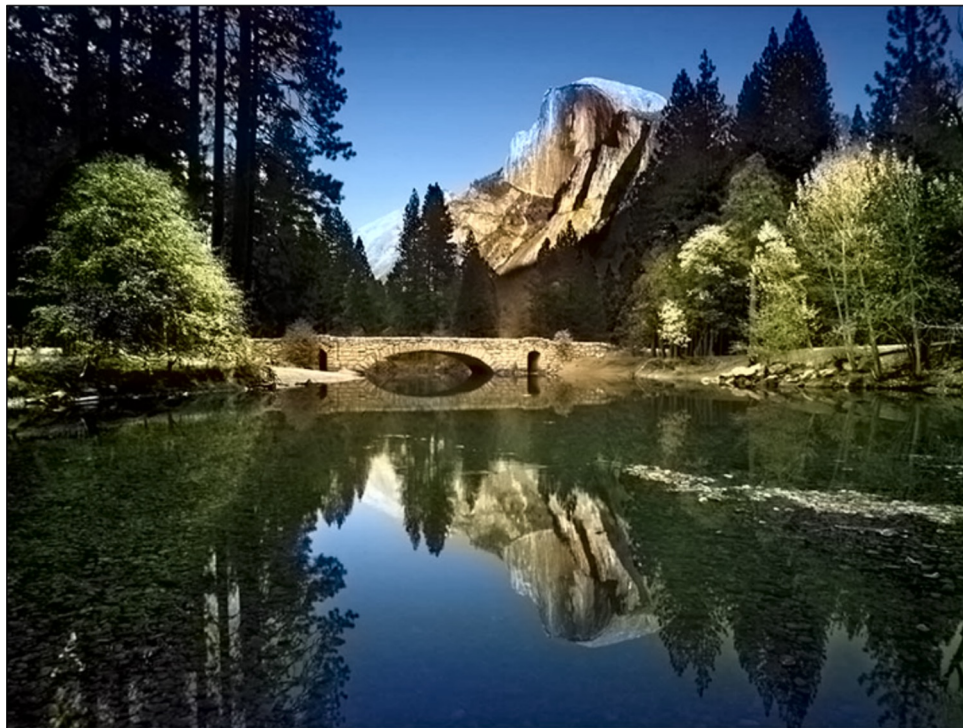

Source: Richard Zhang / Phillip Isola

Pretext task: video coloring

Idea: model the temporal coherence of colors in videos

reference frame



t=0

how should I color these frames?



t=1



t=2



t=3

...

Source: [Vondrick et al., 2018](#)

Pretext task: video coloring

Idea: model the temporal coherence of colors in videos

reference frame



t=0

how should I color these frames?

Should be the same color!



t=1

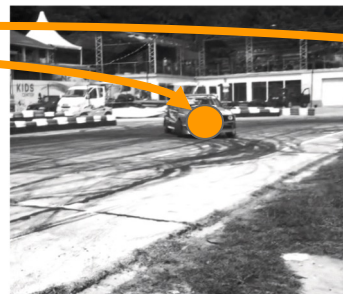

t=2



t=3

...

Hypothesis: learning to color video frames should allow model to learn to track regions or objects without labels!

Source: [Vondrick et al., 2018](#)

Learning to color videos

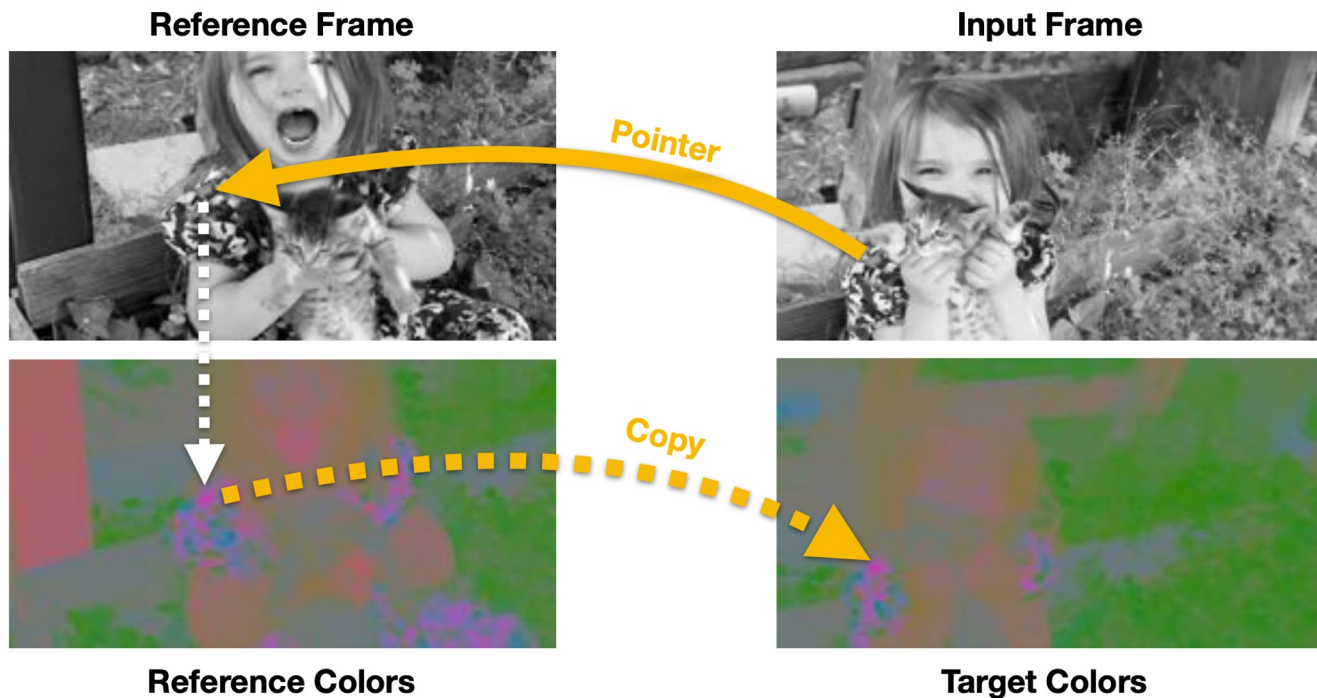

Learning objective:

Establish mappings between reference and target frames in a learned feature space.

Use the mapping as “pointers” to copy the correct color (LAB).

Source: [Vondrick et al., 2018](#)

Learning to color videos

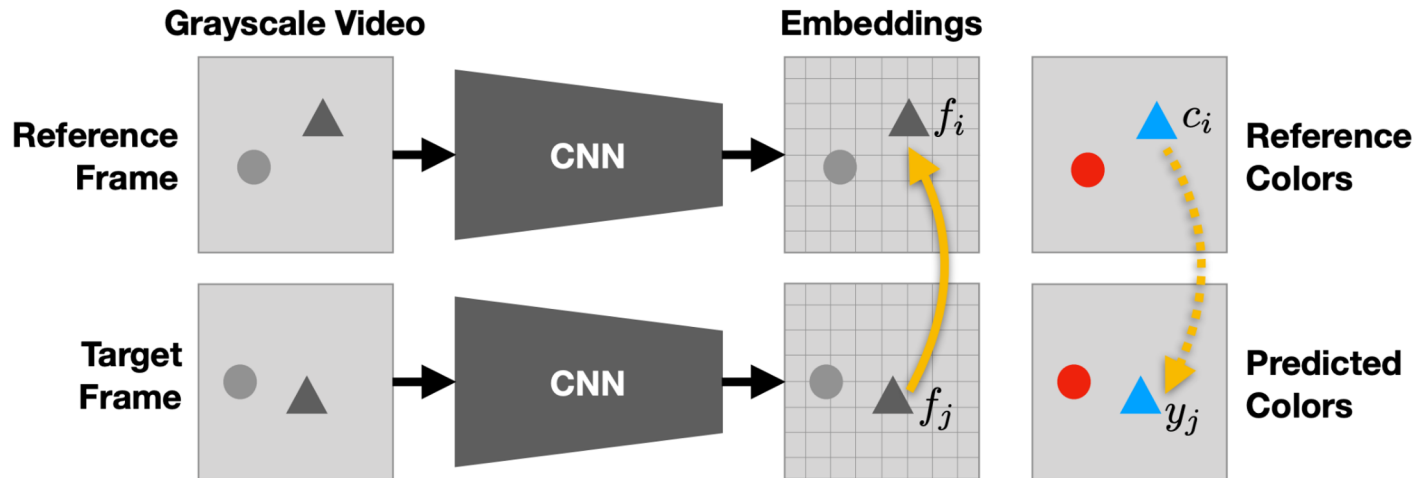

attention map on the reference frame

$$A_{ij} = \frac{\exp(f_i^T f_j)}{\sum_k \exp(f_k^T f_j)}$$

Source: [Vondrick et al., 2018](#)

Learning to color videos

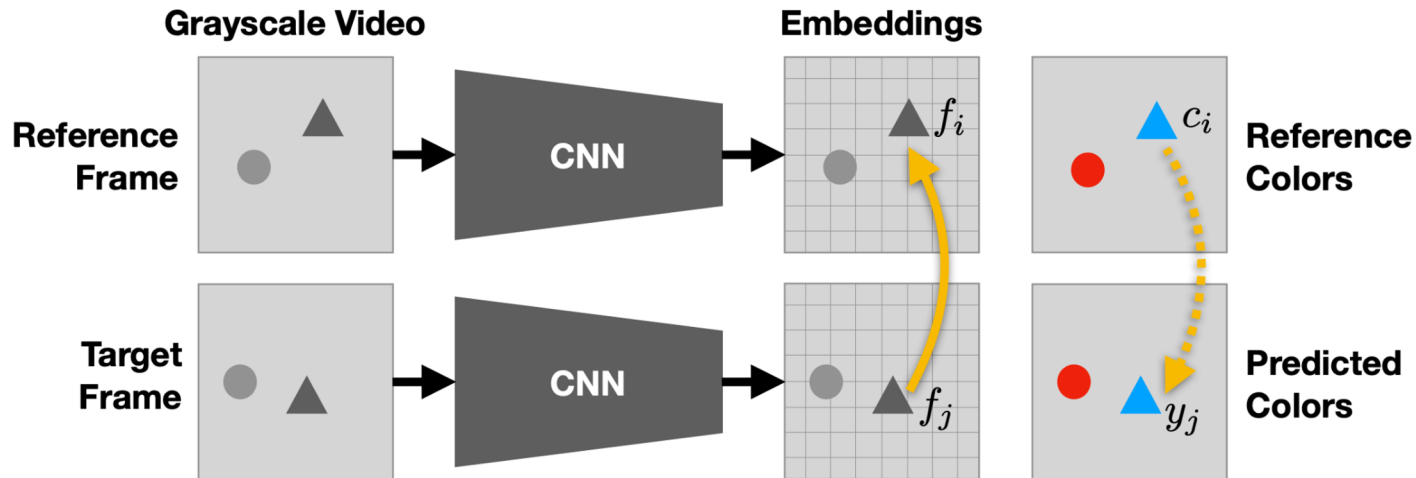

attention map on the reference frame

predicted color = weighted sum of the reference color

$$A_{ij} = \frac{\exp(f_i^T f_j)}{\sum_k \exp(f_k^T f_j)}$$

$$y_j = \sum_i A_{ij} c_i$$

Source: [Vondrick et al., 2018](#)

Learning to color videos

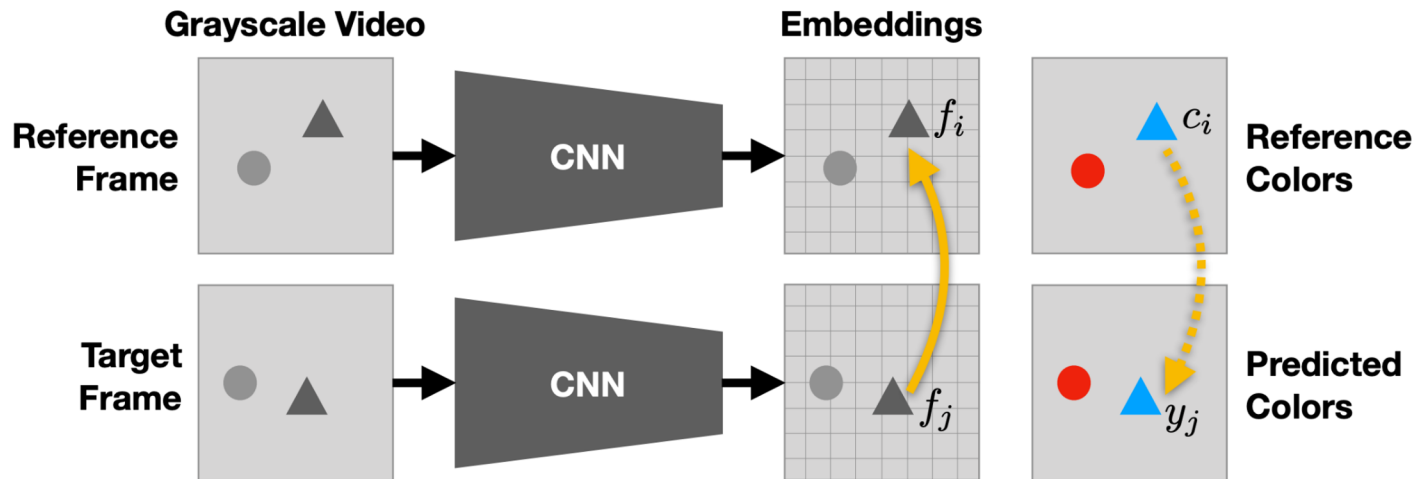

attention map on the reference frame

predicted color = weighted sum of the reference color

loss between predicted color and ground truth color

$$A_{ij} = \frac{\exp(f_i^T f_j)}{\sum_k \exp(f_k^T f_j)}$$

$$y_j = \sum_i A_{ij} c_i$$

$$\min_{\theta} \sum_j \mathcal{L}(y_j, c_j)$$

Source: [Vondrick et al., 2018](#)

Colorizing videos (qualitative)

reference frame



target frames (gray)



predicted color



Source: [Google AI blog post](#)

Colorizing videos (qualitative)

reference frame



target frames (gray)



predicted color



Source: [Google AI blog post](#)

Tracking emerges from colorization

Propagate segmentation masks using learned attention

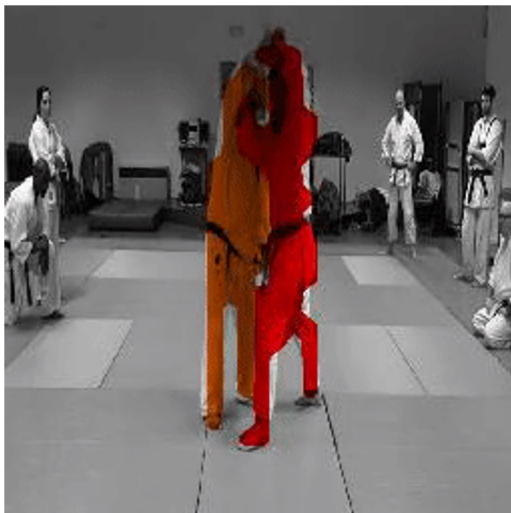

Source: [Google AI blog post](#)

Tracking emerges from colorization

Propagate pose keypoints using learned attention



Source: [Google AI blog post](#)

Summary: pretext tasks from image transformations

- Pretext tasks focus on “visual common sense”, e.g., predict rotations, inpainting, rearrangement, and colorization.
- The models are forced learn good features about natural images, e.g., semantic representation of an object category, in order to solve the pretext tasks.
- We often do not care about the performance of these pretext tasks, but rather how useful the learned features are for downstream tasks (classification, detection, segmentation).

Summary: pretext tasks from image transformations

- Pretext tasks focus on “visual common sense”, e.g., predict rotations, inpainting, rearrangement, and colorization.
- The models are forced learn good features about natural images, e.g., semantic representation of an object category, in order to solve the pretext tasks.
- We often do not care about the performance of these pretext tasks, but rather how useful the learned features are for downstream tasks (classification, detection, segmentation).
- **Problems: 1) coming up with individual pretext tasks is tedious, and 2) the learned representations may not be general.**

Pretext tasks from image transformations

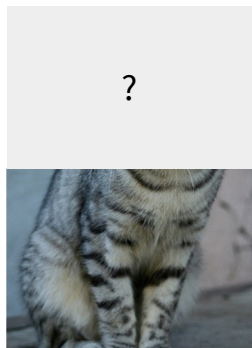
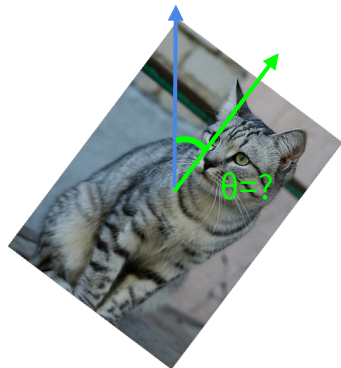
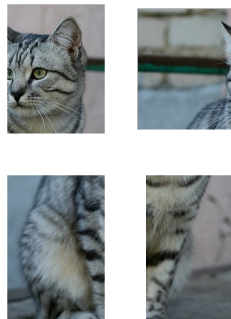

image completion



rotation prediction



“jigsaw puzzle”



colorization

Learned representations may be tied to a specific pretext task!

Can we come up with a more general pretext task?

A more general pretext task?

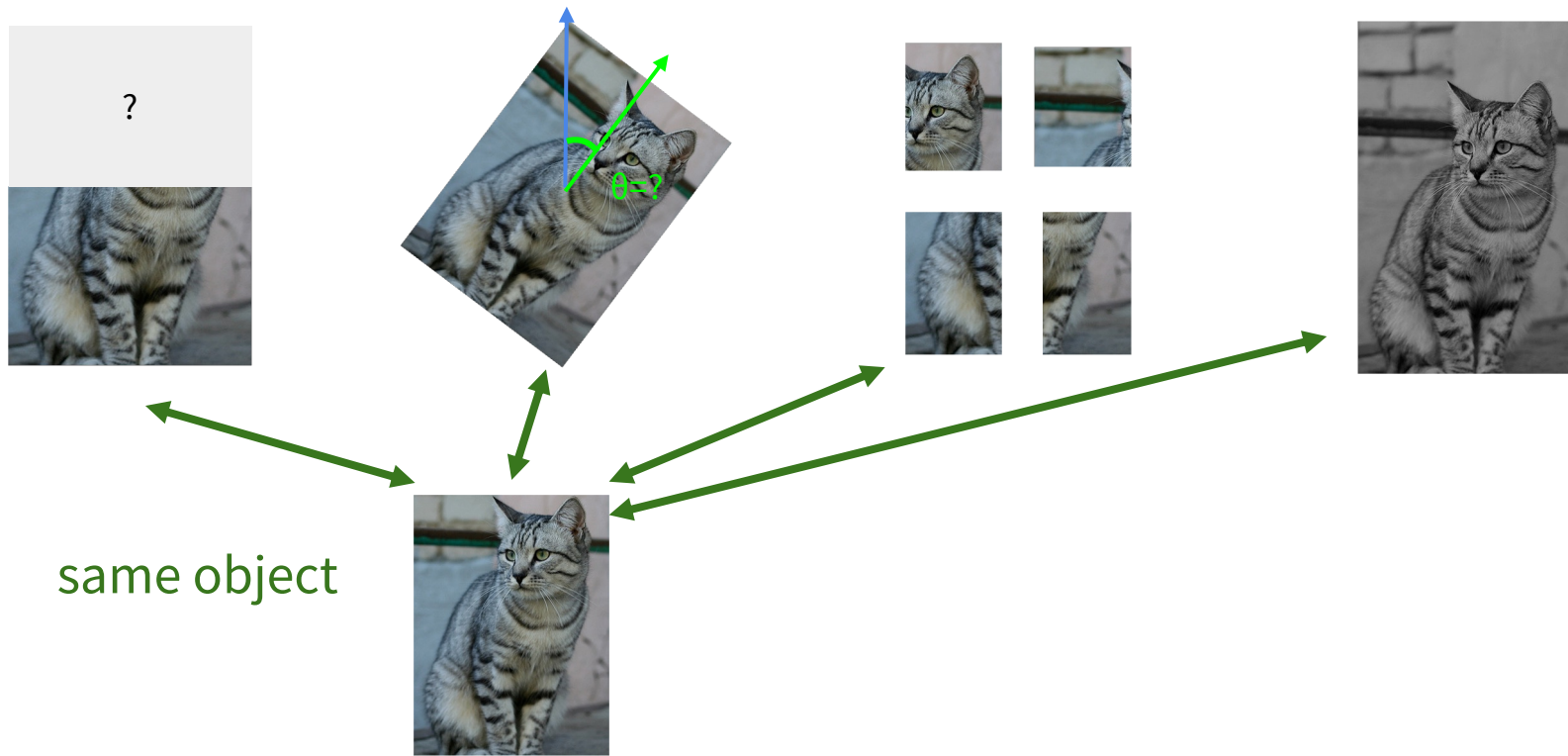

A more general pretext task?

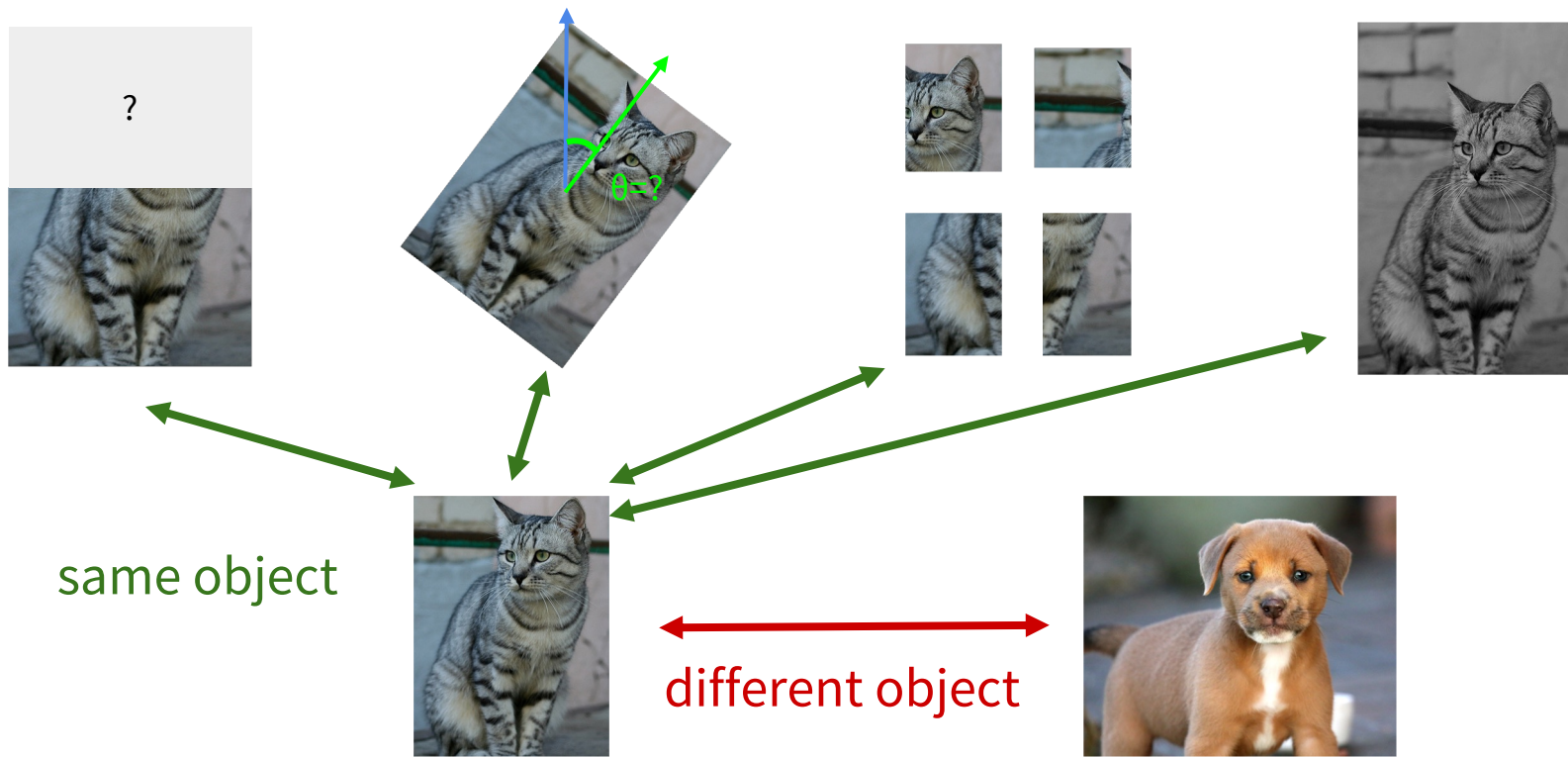

Contrastive Representation Learning

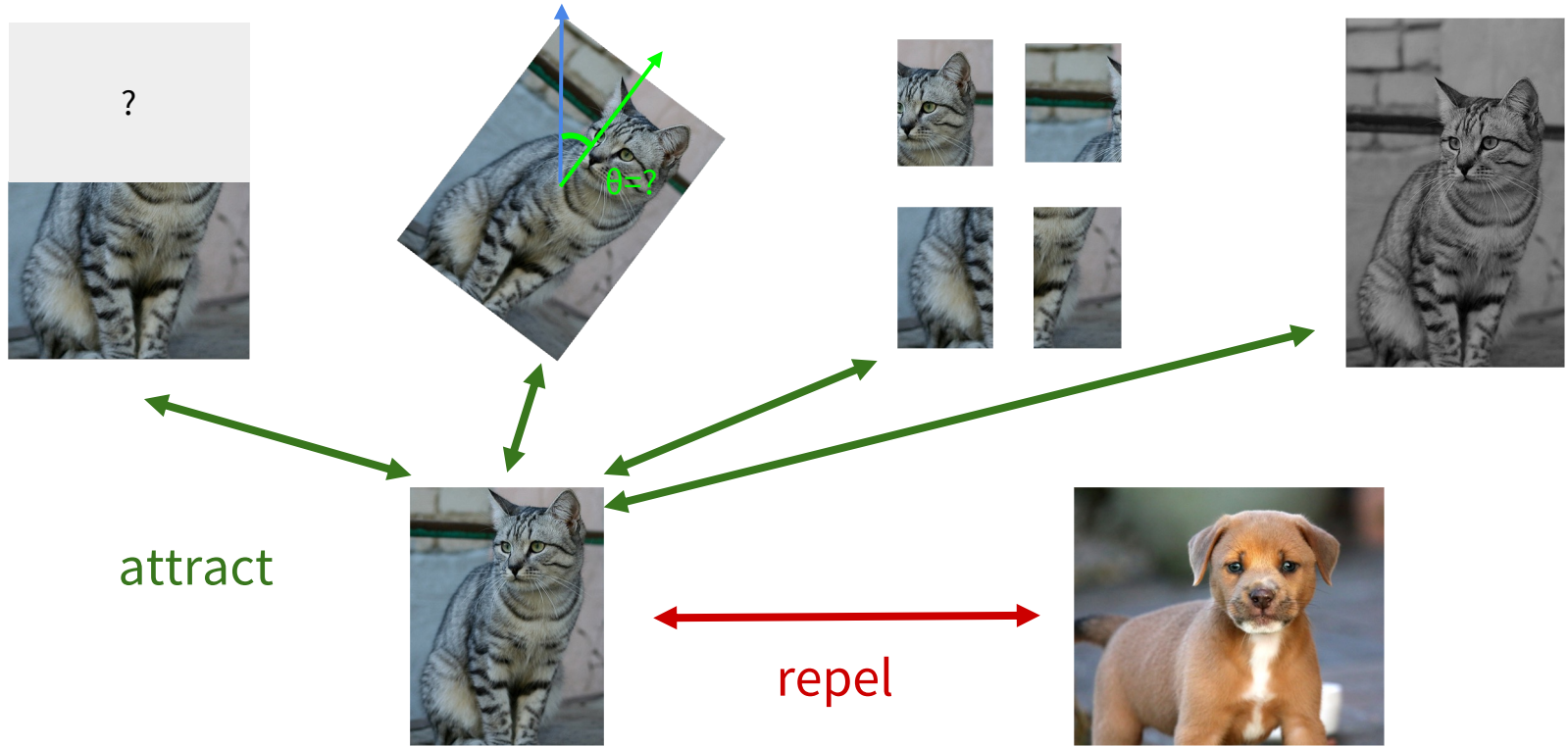

Today's Agenda

Pretext tasks from image transformations

- Rotation, inpainting, rearrangement, coloring

Contrastive representation learning

- Intuition and formulation
- Instance contrastive learning: SimCLR and MOCO
- Sequence contrastive learning: CPC

Contrastive Representation Learning

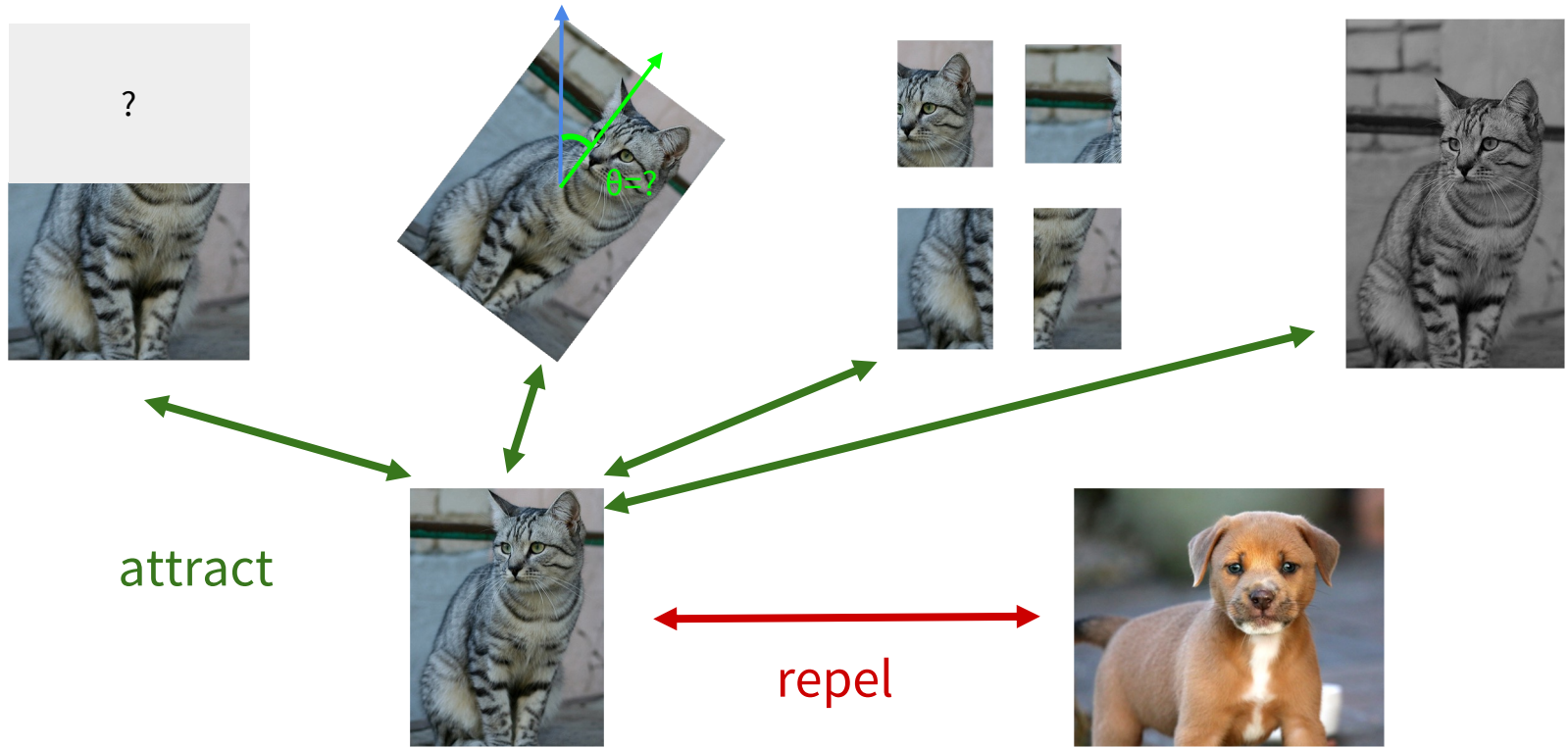

Contrastive Representation Learning

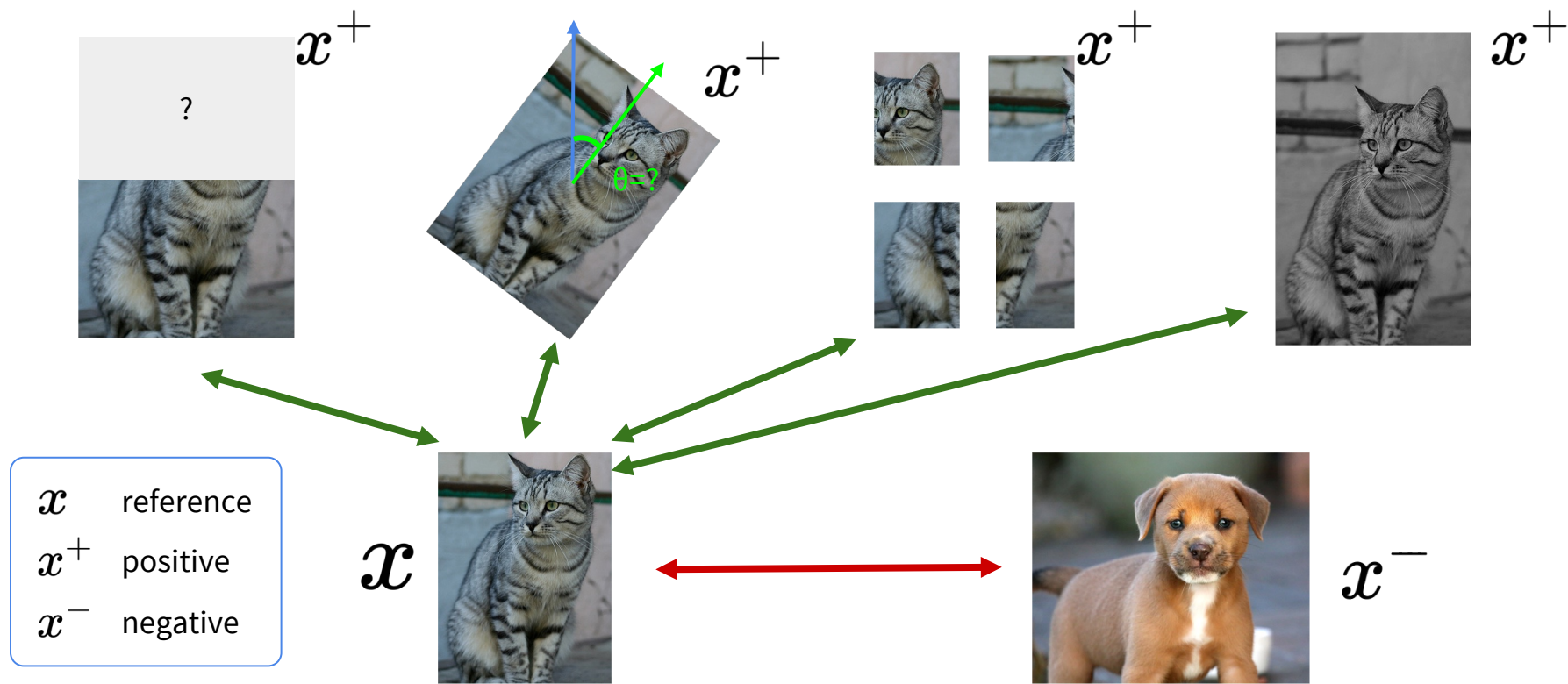

A formulation of contrastive learning

What we want:

$$\text{score}(f(x), f(x^+)) \gg \text{score}(f(x), f(x^-))$$

x : reference sample; x^+ positive sample; x^- negative sample

Given a chosen score function, we aim to learn an encoder function f that yields high score for positive pairs (x, x^+) and low scores for negative pairs (x, x^-) .

A formulation of contrastive learning

Loss function given 1 positive sample and $N - 1$ negative samples:

$$L = -\mathbb{E}_X \left[\log \frac{\exp(s(f(x), f(x^+)))}{\exp(s(f(x), f(x^+))) + \sum_{j=1}^{N-1} \exp(s(f(x), f(x_j^-)))} \right]$$

A formulation of contrastive learning

Loss function given 1 positive sample and N - 1 negative samples:

$$L = -\mathbb{E}_X \left[\log \frac{\exp(s(f(x), f(x^+)))}{\exp(s(f(x), f(x^+))) + \sum_{j=1}^{N-1} \exp(s(f(x), f(x_j^-)))} \right]$$



x



x^+



x



x_1^-



x_2^-



x_3^-

...

A formulation of contrastive learning

Loss function given 1 positive sample and $N - 1$ negative samples:

$$L = -\mathbb{E}_X \left[\log \frac{\overbrace{\exp(s(f(x), f(x^+)))}^{\text{score for the positive pair}}}{\underbrace{\exp(s(f(x), f(x^+)))}_{\text{score for the positive pair}} + \underbrace{\sum_{j=1}^{N-1} \exp(s(f(x), f(x_j^-)))}_{\text{score for the N-1 negative pairs}}} \right]$$

This seems familiar ...

A formulation of contrastive learning

Loss function given 1 positive sample and N - 1 negative samples:

$$L = -\mathbb{E}_X \left[\log \frac{\overbrace{\exp(s(f(x), f(x^+)))}^{\text{score for the positive pair}}}{\underbrace{\exp(s(f(x), f(x^+)))}_{\text{score for the positive pair}} + \underbrace{\sum_{j=1}^{N-1} \exp(s(f(x), f(x_j^-)))}_{\text{score for the N-1 negative pairs}}} \right]$$

This seems familiar ...

Cross entropy loss for a N-way softmax classifier!

I.e., learn to find the positive sample from the N samples

A formulation of contrastive learning

Loss function given 1 positive sample and $N - 1$ negative samples:

$$L = -\mathbb{E}_X \left[\log \frac{\exp(s(f(x), f(x^+)))}{\exp(s(f(x), f(x^+))) + \sum_{j=1}^{N-1} \exp(s(f(x), f(x_j^-)))} \right]$$

Commonly known as the InfoNCE loss ([van den Oord et al., 2018](#))

A lower bound on the mutual information between $f(x)$ and $f(x^+)$

$$MI[f(x), f(x^+)] - \log(N) \geq -L$$

The larger the negative sample size (N), the tighter the bound

Detailed derivation: [Poole et al., 2019](#)

SimCLR: A Simple Framework for Contrastive Learning

Cosine similarity as the score function:

$$s(u, v) = \frac{u^T v}{\|u\| \|v\|}$$

Use a projection network $g(\cdot)$ to project features to a space where contrastive learning is applied

Generate positive samples through data augmentation:

- random cropping, random color distortion, and random blur.

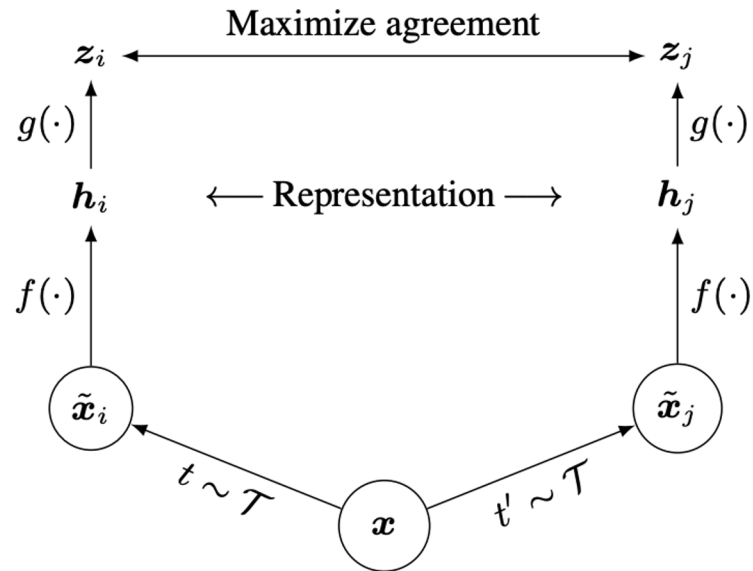

Source: [Chen et al., 2020](#)

SimCLR: generating positive samples from data augmentation



(a) Original



(b) Crop and resize



(c) Crop, resize (and flip)



(d) Color distort. (drop)

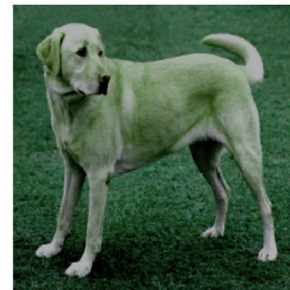

(e) Color distort. (jitter)



(f) Rotate $\{90^\circ, 180^\circ, 270^\circ\}$



(g) Cutout



(h) Gaussian noise



(i) Gaussian blur



(j) Sobel filtering

Source: [Chen et al., 2020](#)

SimCLR

Generate a positive pair
by sampling data
augmentation functions

Algorithm 1 SimCLR's main learning algorithm.

input: batch size N , constant τ , structure of f, g, \mathcal{T} .

for sampled minibatch $\{\mathbf{x}_k\}_{k=1}^N$ **do**

for all $k \in \{1, \dots, N\}$ **do**

 draw two augmentation functions $t \sim \mathcal{T}, t' \sim \mathcal{T}$

 # the first augmentation

$\tilde{\mathbf{x}}_{2k-1} = t(\mathbf{x}_k)$

$\mathbf{h}_{2k-1} = f(\tilde{\mathbf{x}}_{2k-1})$

 # representation

$\mathbf{z}_{2k-1} = g(\mathbf{h}_{2k-1})$

 # projection

 # the second augmentation

$\tilde{\mathbf{x}}_{2k} = t'(\mathbf{x}_k)$

$\mathbf{h}_{2k} = f(\tilde{\mathbf{x}}_{2k})$

 # representation

$\mathbf{z}_{2k} = g(\mathbf{h}_{2k})$

 # projection

end for

for all $i \in \{1, \dots, 2N\}$ and $j \in \{1, \dots, 2N\}$ **do**

$s_{i,j} = \mathbf{z}_i^\top \mathbf{z}_j / (\|\mathbf{z}_i\| \|\mathbf{z}_j\|)$ # pairwise similarity

end for

define $\ell(i, j)$ as $\ell(i, j) = -\log \frac{\exp(s_{i,j}/\tau)}{\sum_{k=1}^{2N} \mathbb{1}_{[k \neq i]} \exp(s_{i,k}/\tau)}$

$\mathcal{L} = \frac{1}{2N} \sum_{k=1}^N [\ell(2k-1, 2k) + \ell(2k, 2k-1)]$

 update networks f and g to minimize \mathcal{L}

end for

return encoder network $f(\cdot)$, and throw away $g(\cdot)$

*We use a slightly different formulation in the assignment. You should follow the assignment instructions.

Source: [Chen et al., 2020](#)

SimCLR

Algorithm 1 SimCLR's main learning algorithm.

input: batch size N , constant τ , structure of f, g, \mathcal{T} .

for sampled minibatch $\{\mathbf{x}_k\}_{k=1}^N$ **do**

for all $k \in \{1, \dots, N\}$ **do**

 draw two augmentation functions $t \sim \mathcal{T}, t' \sim \mathcal{T}$

 # the first augmentation

$\tilde{\mathbf{x}}_{2k-1} = t(\mathbf{x}_k)$

$\mathbf{h}_{2k-1} = f(\tilde{\mathbf{x}}_{2k-1})$

 # representation

$\mathbf{z}_{2k-1} = g(\mathbf{h}_{2k-1})$

 # projection

 # the second augmentation

$\tilde{\mathbf{x}}_{2k} = t'(\mathbf{x}_k)$

$\mathbf{h}_{2k} = f(\tilde{\mathbf{x}}_{2k})$

 # representation

$\mathbf{z}_{2k} = g(\mathbf{h}_{2k})$

 # projection

end for

for all $i \in \{1, \dots, 2N\}$ and $j \in \{1, \dots, 2N\}$ **do**

$s_{i,j} = \mathbf{z}_i^\top \mathbf{z}_j / (\|\mathbf{z}_i\| \|\mathbf{z}_j\|)$ # pairwise similarity

end for

define $\ell(i, j)$ as $\ell(i, j) = -\log \frac{\exp(s_{i,j}/\tau)}{\sum_{k=1}^{2N} \mathbb{1}_{[k \neq i]} \exp(s_{i,k}/\tau)}$

$\mathcal{L} = \frac{1}{2N} \sum_{k=1}^N [\ell(2k-1, 2k) + \ell(2k, 2k-1)]$

 update networks f and g to minimize \mathcal{L}

end for

return encoder network $f(\cdot)$, and throw away $g(\cdot)$

Generate a positive pair
by sampling data
augmentation functions

*We use a slightly different
formulation in the
assignment. You should follow
the assignment instructions.

InfoNCE loss:
Use all non-positive
samples in the batch
as x^-

Source: [Chen et al., 2020](#)

SimCLR

Algorithm 1 SimCLR's main learning algorithm.

input: batch size N , constant τ , structure of f, g, \mathcal{T} .

for sampled minibatch $\{\mathbf{x}_k\}_{k=1}^N$ **do**

for all $k \in \{1, \dots, N\}$ **do**

 draw two augmentation functions $t \sim \mathcal{T}, t' \sim \mathcal{T}$

 # the first augmentation

$\tilde{\mathbf{x}}_{2k-1} = t(\mathbf{x}_k)$

$\mathbf{h}_{2k-1} = f(\tilde{\mathbf{x}}_{2k-1})$

 # representation

$\mathbf{z}_{2k-1} = g(\mathbf{h}_{2k-1})$

 # projection

 # the second augmentation

$\tilde{\mathbf{x}}_{2k} = t'(\mathbf{x}_k)$

$\mathbf{h}_{2k} = f(\tilde{\mathbf{x}}_{2k})$

 # representation

$\mathbf{z}_{2k} = g(\mathbf{h}_{2k})$

 # projection

end for

for all $i \in \{1, \dots, 2N\}$ and $j \in \{1, \dots, 2N\}$ **do**

$s_{i,j} = \mathbf{z}_i^\top \mathbf{z}_j / (\|\mathbf{z}_i\| \|\mathbf{z}_j\|)$ # pairwise similarity

end for

define $\ell(i, j)$ as $\ell(i, j) = -\log \frac{\exp(s_{i,j}/\tau)}{\sum_{k=1}^{2N} \mathbb{1}_{[k \neq i]} \exp(s_{i,k}/\tau)}$

$\mathcal{L} = \frac{1}{2N} \sum_{k=1}^N [\ell(2k-1, 2k) + \ell(2k, 2k-1)]$

 update networks f and g to minimize \mathcal{L}

end for

return encoder network $f(\cdot)$, and throw away $g(\cdot)$

*We use a slightly different formulation in the assignment. You should follow the assignment instructions.

Generate a positive pair by sampling data augmentation functions

Iterate through and use each of the $2N$ sample as reference, compute average loss

InfoNCE loss: Use all non-positive samples in the batch as x^-

Source: [Chen et al., 2020](#)

SimCLR: mini-batch training

$$s_{i,j} = \frac{z_i^T z_j}{\|z_i\| \|z_j\|}$$

“Affinity matrix”

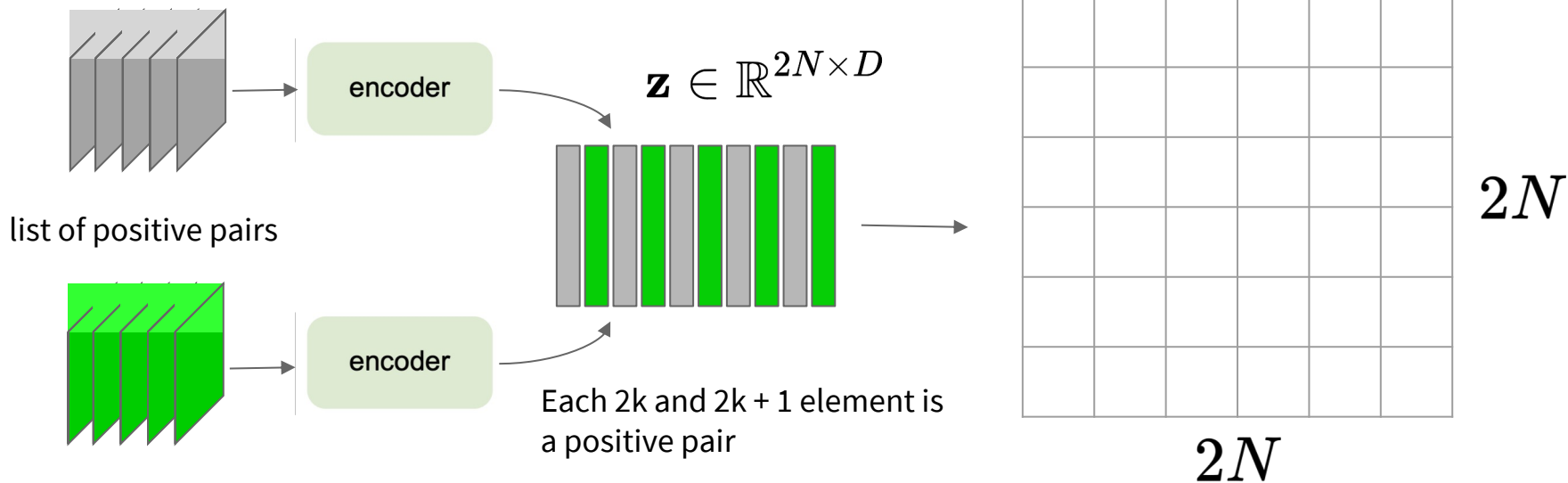

*We use a slightly different formulation in the assignment.
You should follow the assignment instructions.

SimCLR: mini-batch training

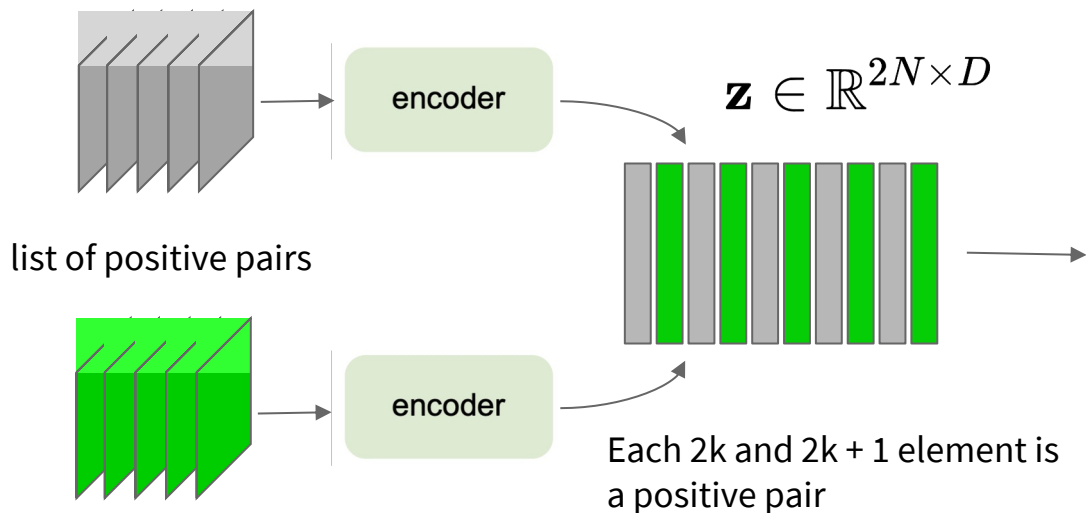

$$s_{i,j} = \frac{z_i^T z_j}{\|z_i\| \|z_j\|}$$

“Affinity matrix”

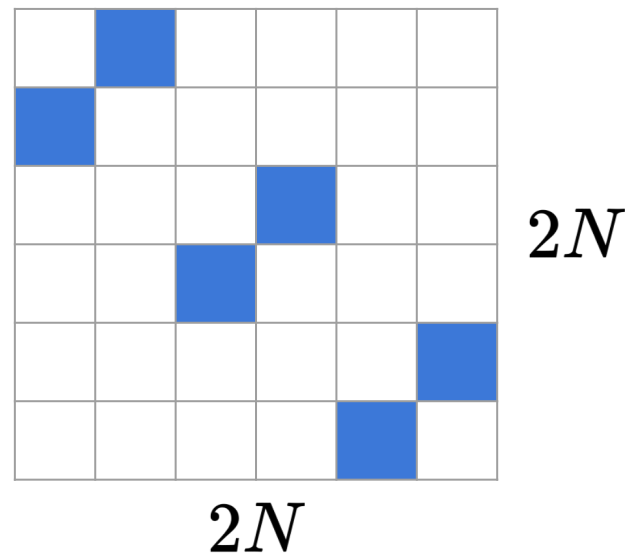

 = classification label for each row

*We use a slightly different formulation in the assignment.
You should follow the assignment instructions.

Training linear classifier on SimCLR features

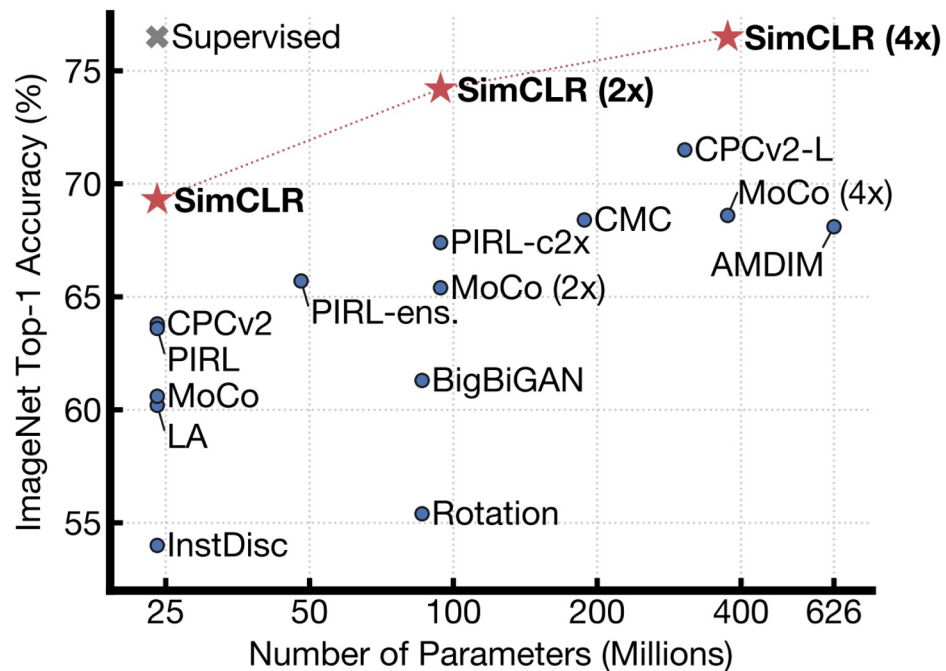

Train feature encoder on ImageNet (entire training set) using SimCLR.

Freeze feature encoder, train a linear classifier on top with labeled data.

Source: [Chen et al., 2020](#)

Semi-supervised learning on SimCLR features

Method	Architecture	Label fraction	
		1%	10%
Supervised baseline	ResNet-50	48.4	80.4
<i>Methods using other label-propagation:</i>			
Pseudo-label	ResNet-50	51.6	82.4
VAT+Entropy Min.	ResNet-50	47.0	83.4
UDA (w. RandAug)	ResNet-50	-	88.5
FixMatch (w. RandAug)	ResNet-50	-	89.1
S4L (Rot+VAT+En. M.)	ResNet-50 (4×)	-	91.2
<i>Methods using representation learning only:</i>			
InstDisc	ResNet-50	39.2	77.4
BigBiGAN	RevNet-50 (4×)	55.2	78.8
PIRL	ResNet-50	57.2	83.8
CPC v2	ResNet-161(*)	77.9	91.2
SimCLR (ours)	ResNet-50	75.5	87.8
SimCLR (ours)	ResNet-50 (2×)	83.0	91.2
SimCLR (ours)	ResNet-50 (4×)	85.8	92.6

Table 7. ImageNet accuracy of models trained with few labels.

Train feature encoder on ImageNet (entire training set) using SimCLR.

Finetune the encoder with 1% / 10% of labeled data on ImageNet.

Source: [Chen et al., 2020](#)

SimCLR design choices: projection head

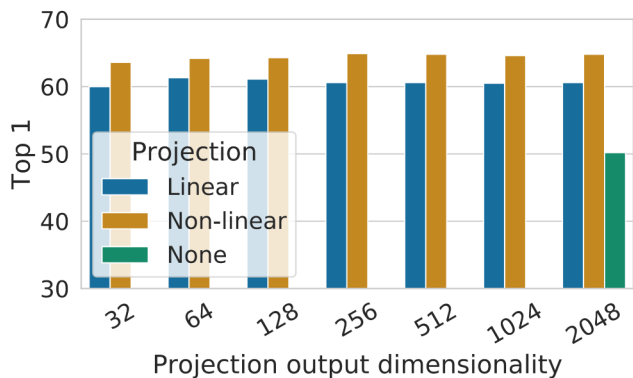

Linear / non-linear projection heads improve representation learning.

A possible explanation:

- contrastive learning objective may discard useful information for downstream tasks
- representation space z is trained to be invariant to data transformation.
- by leveraging the projection head $g(\cdot)$, more information can be preserved in the h representation space

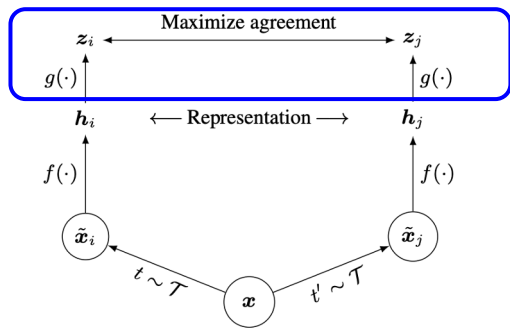

Source: [Chen et al., 2020](#)

SimCLR design choices: large batch size

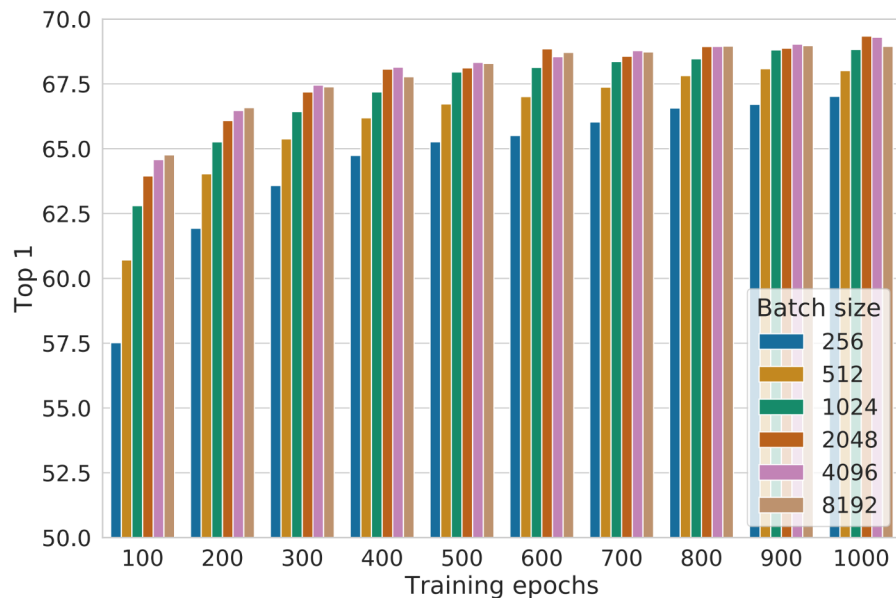

Figure 9. Linear evaluation models (ResNet-50) trained with different batch size and epochs. Each bar is a single run from scratch.¹⁰

Large training batch size is crucial for SimCLR!

Large batch size causes large memory footprint during backpropagation:
requires distributed training on TPUs
(ImageNet experiments)

$$MI[f(x), f(x^+)] - \log(N) \geq -L$$

Source: [Chen et al., 2020](#)

Momentum Contrastive Learning (MoCo)

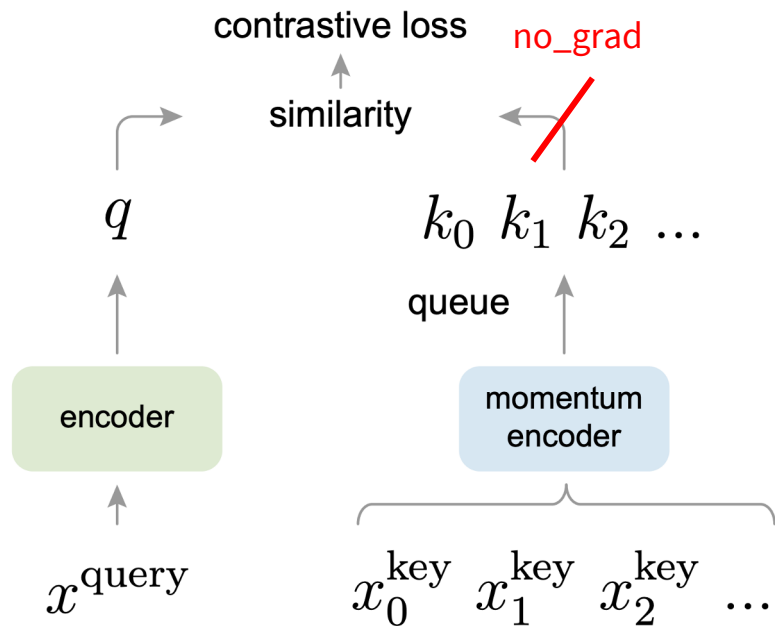

Key differences to SimCLR:

- Keep a running **queue** of keys (negative samples).
- Compute gradients and update the encoder **only through the queries**.
- Decouple min-batch size with the number of keys: can support a **large number of negative samples**.

Source: [He et al., 2020](#)

Momentum Contrastive Learning (MoCo)

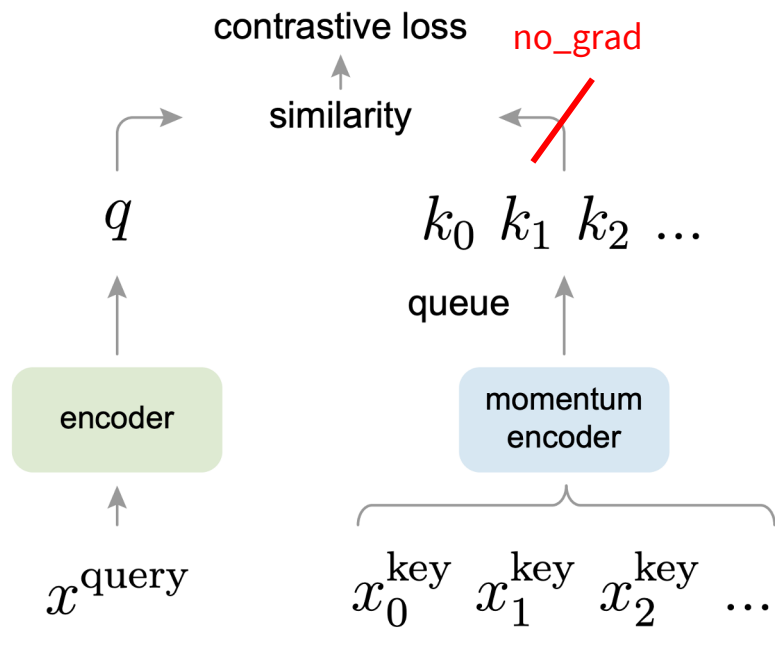

Key differences to SimCLR:

- Keep a running **queue** of keys (negative samples).
- Compute gradients and update the encoder **only through the queries**.
- Decouple min-batch size with the number of keys: can support a **large number of negative samples**.
- The key encoder is **slowly progressing** through the momentum update rules:
$$\theta_k \leftarrow m\theta_k + (1 - m)\theta_q$$

Source: [He et al., 2020](#)

MoCo

Algorithm 1 Pseudocode of MoCo in a PyTorch-like style.

```
# f_q, f_k: encoder networks for query and key
# queue: dictionary as a queue of K keys (CxK)
# m: momentum
# t: temperature

f_k.params = f_q.params # initialize
for x in loader: # load a minibatch x with N samples
    x_q = aug(x) # a randomly augmented version
    x_k = aug(x) # another randomly augmented version

    q = f_q.forward(x_q) # queries: NxK
    k = f_k.forward(x_k) # keys: NxK
    k = k.detach() # no gradient to keys

    # positive logits: Nx1
    l_pos = bmm(q.view(N,1,C), k.view(N,C,1))

    # negative logits: NxK
    l_neg = mm(q.view(N,C), queue.view(C,K))

    # logits: Nx(1+K)
    logits = cat([l_pos, l_neg], dim=1)

    # contrastive loss, Eqn.(1)
    labels = zeros(N) # positives are the 0-th
    loss = CrossEntropyLoss(logits/t, labels)

    # SGD update: query network
    loss.backward()
    update(f_q.params)

    # momentum update: key network
    f_k.params = m*f_k.params+(1-m)*f_q.params

    # update dictionary
    enqueue(queue, k) # enqueue the current minibatch
    dequeue(queue) # dequeue the earliest minibatch
```

Generate a positive pair
by sampling data
augmentation functions

No gradient through
the key

Update the FIFO negative
sample queue

Use the running
queue of keys as the
negative samples

InfoNCE loss

Update f_k through
momentum

bmm: batch matrix multiplication; mm: matrix multiplication; cat: concatenation.

Source: [He et al., 2020](#)

“MoCo V2”

Improved Baselines with Momentum Contrastive Learning

Xinlei Chen Haoqi Fan Ross Girshick Kaiming He
Facebook AI Research (FAIR)

A hybrid of ideas from SimCLR and MoCo:

- From SimCLR: non-linear projection head and strong data augmentation.
- From MoCo: momentum-updated queues that allow training on a large number of negative samples (no TPU required!).

Source: [Chen et al., 2020](#)

MoCo vs. SimCLR vs. MoCo V2

case	unsup. pre-train				ImageNet acc.	VOC detection		
	MLP	aug+	cos	epochs		AP ₅₀	AP	AP ₇₅
supervised					76.5	81.3	53.5	58.8
MoCo v1				200	60.6	81.5	55.9	62.6
(a)	✓			200	66.2	82.0	56.4	62.6
(b)		✓		200	63.4	82.2	56.8	63.2
(c)	✓	✓		200	67.3	82.5	57.2	63.9
(d)	✓	✓	✓	200	67.5	82.4	57.0	63.6
(e)	✓	✓	✓	800	71.1	82.5	57.4	64.0

Table 1. **Ablation of MoCo baselines**, evaluated by ResNet-50 for (i) ImageNet linear classification, and (ii) fine-tuning VOC object detection (mean of 5 trials). “**MLP**”: with an MLP head; “**aug+**”: with extra blur augmentation; “**cos**”: cosine learning rate schedule.

Key takeaways:

- Non-linear projection head and strong data augmentation are crucial for contrastive learning.

Source: [Chen et al., 2020](#)

MoCo vs. SimCLR vs. MoCo V2

case	unsup. pre-train					ImageNet acc.
	MLP	aug+	cos	epochs	batch	
MoCo v1 [6]				200	256	60.6
SimCLR [2]	✓	✓	✓	200	256	61.9
SimCLR [2]	✓	✓	✓	200	8192	66.6
MoCo v2	✓	✓	✓	200	256	67.5
<i>results of longer unsupervised training follow:</i>						
SimCLR [2]	✓	✓	✓	1000	4096	69.3
MoCo v2	✓	✓	✓	800	256	71.1

Table 2. **MoCo vs. SimCLR**: ImageNet linear classifier accuracy (**ResNet-50, 1-crop 224×224**), trained on features from unsupervised pre-training. “aug+” in SimCLR includes blur and stronger color distortion. SimCLR ablations are from Fig. 9 in [2] (we thank the authors for providing the numerical results).

Key takeaways:

- Non-linear projection head and strong data augmentation are crucial for contrastive learning.
- Decoupling mini-batch size with negative sample size allows MoCo-V2 to outperform SimCLR with smaller batch size (256 vs. 8192).

Source: [Chen et al., 2020](#)

MoCo vs. SimCLR vs. MoCo V2

mechanism	batch	memory / GPU	time / 200-ep.
MoCo	256	5.0G	53 hrs
end-to-end	256	7.4G	65 hrs
end-to-end	4096	93.0G [†]	n/a

Table 3. **Memory and time cost** in 8 V100 16G GPUs, implemented in PyTorch. [†]: based on our estimation.

Key takeaways:

- Non-linear projection head and strong data augmentation are crucial for contrastive learning.
- Decoupling mini-batch size with negative sample size allows MoCo-V2 to outperform SimCLR with smaller batch size (256 vs. 8192).
- ... all with much smaller memory footprint! (“end-to-end” means SimCLR here)

Source: [Chen et al., 2020](#)

Instance vs. Sequence Contrastive Learning

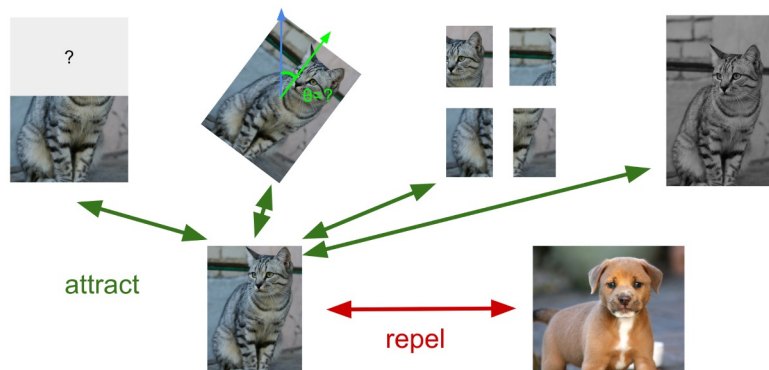

Instance-level contrastive learning:
contrastive learning based on
positive & negative instances.
Examples: SimCLR, MoCo

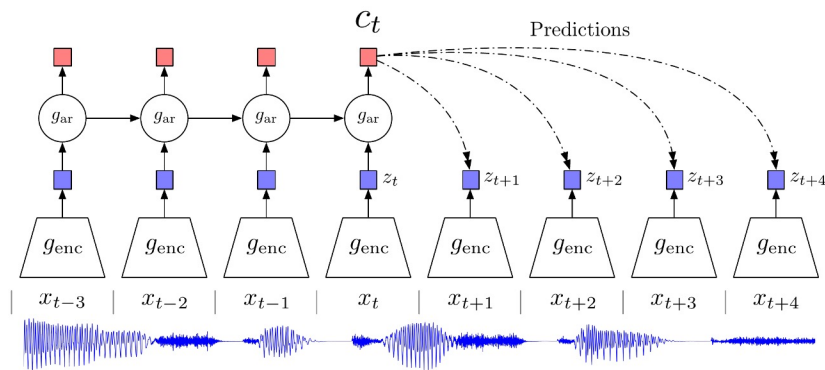

Source: [van den Oord et al., 2018](#)

Sequence-level contrastive learning:
contrastive learning based on
sequential / temporal orders.
Example: Contrastive Predictive Coding (CPC)

Contrastive Predictive Coding (CPC)

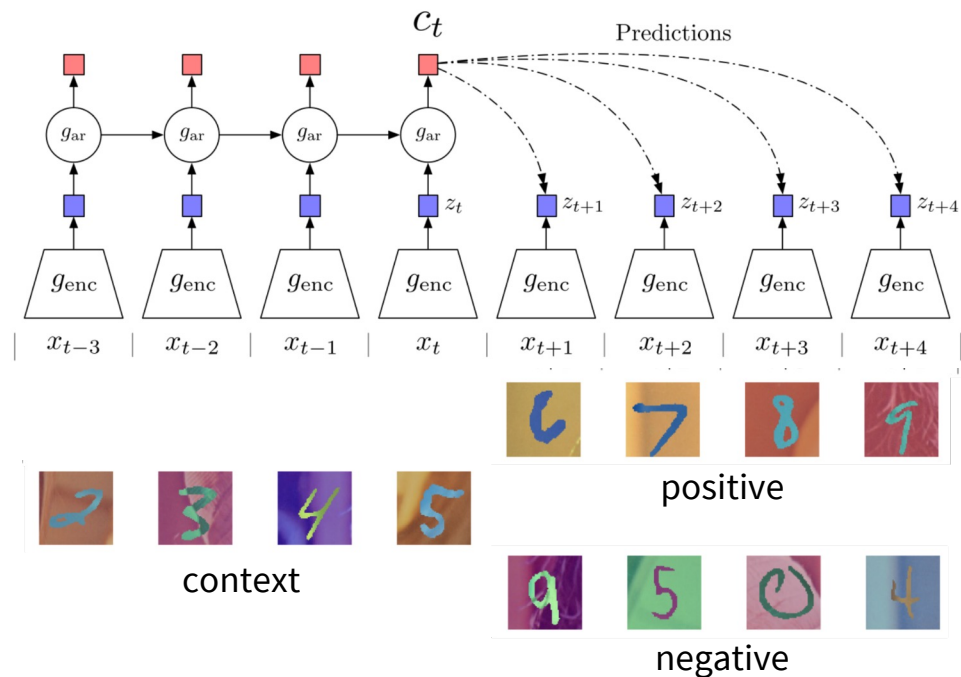

Contrastive: contrast between “right” and “wrong” sequences using contrastive learning.

Predictive: the model has to predict future patterns given the current context.

Coding: the model learns useful feature vectors, or “code”, for downstream tasks, similar to other self-supervised methods.

Figure [source](#)

Source: [van den Oord et al., 2018](#),

Contrastive Predictive Coding (CPC)

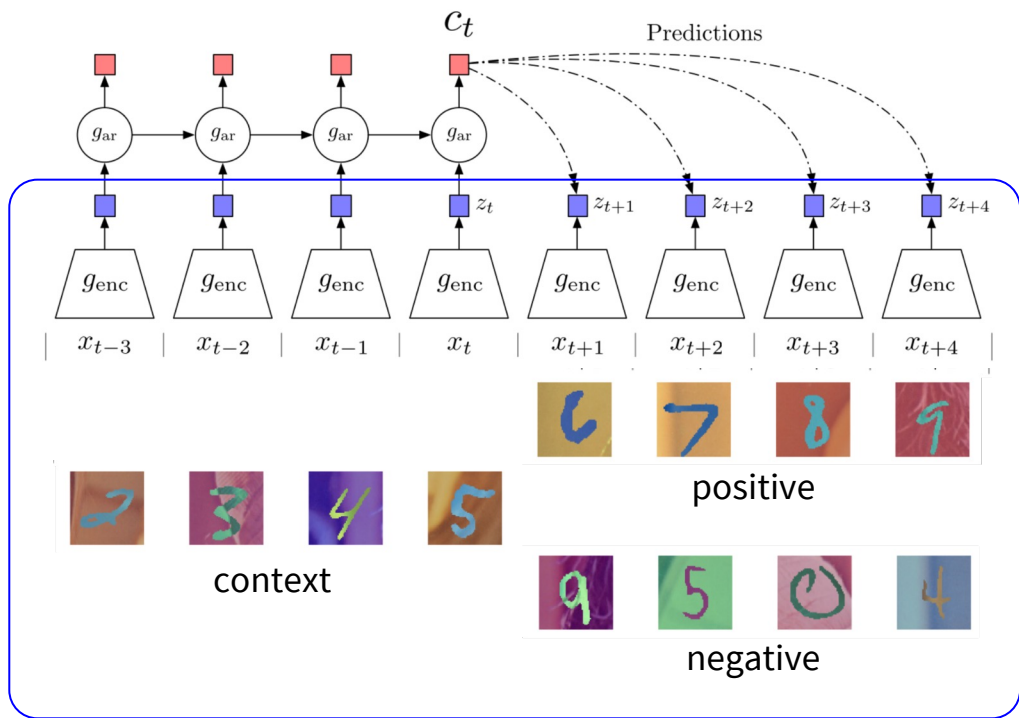

1. Encode all samples in a sequence into vectors $z_t = g_{enc}(x_t)$

Figure [source](#)

Source: [van den Oord et al., 2018](#),

Contrastive Predictive Coding (CPC)

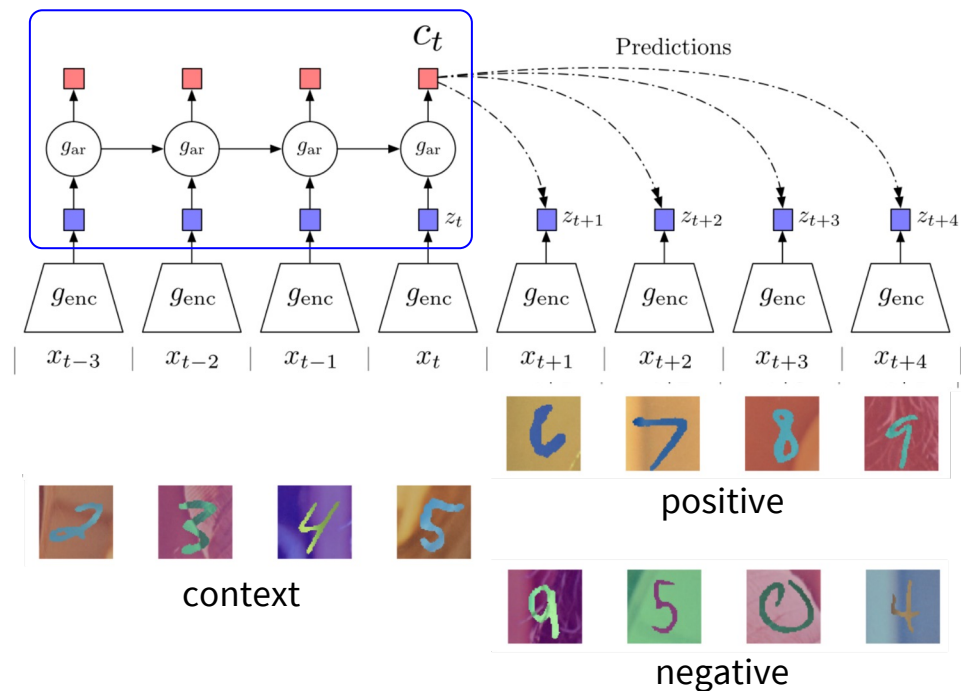

1. Encode all samples in a sequence into vectors $z_t = g_{enc}(x_t)$

2. Summarize context (e.g., half of a sequence) into a context code c_t using an auto-regressive model (g_{ar}). The original paper uses GRU-RNN here.

Figure [source](#)

Source: [van den Oord et al., 2018](#),

Contrastive Predictive Coding (CPC)

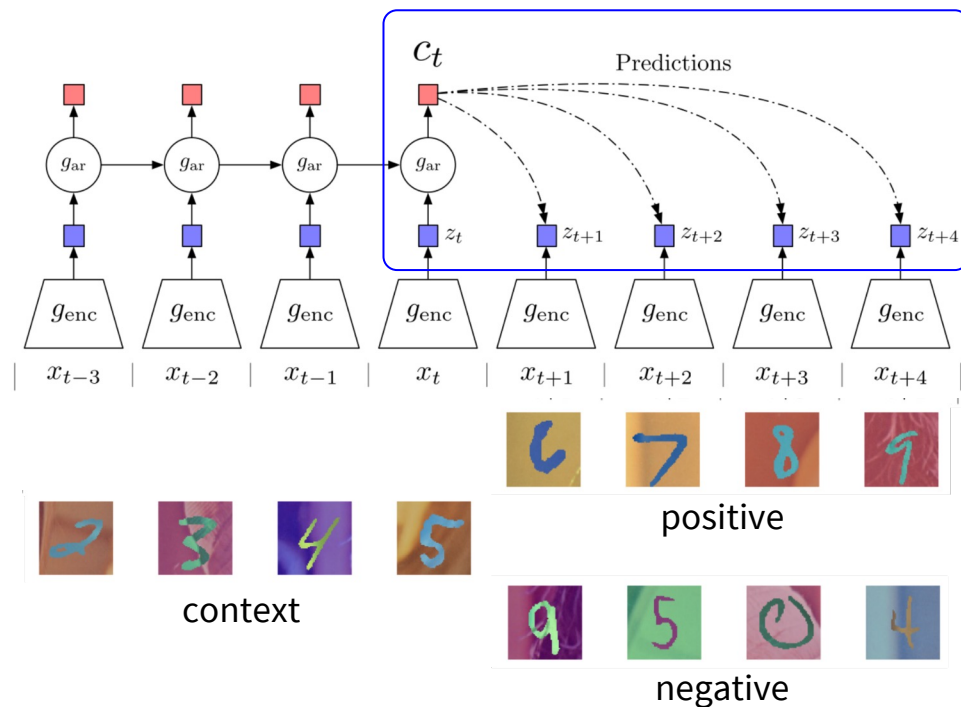

1. Encode all samples in a sequence into vectors $z_t = g_{enc}(x_t)$
2. Summarize context (e.g., half of a sequence) into a context code c_t using an auto-regressive model (g_{ar})

3. Compute InfoNCE loss between the context c_t and future code z_{t+k} using the following time-dependent score function:

$$s_k(z_{t+k}, c_t) = z_{t+k}^T W_k c_t$$

, where W_k is a trainable matrix.

Figure [source](#)

Source: [van den Oord et al., 2018](#),

CPC example: modeling audio sequences

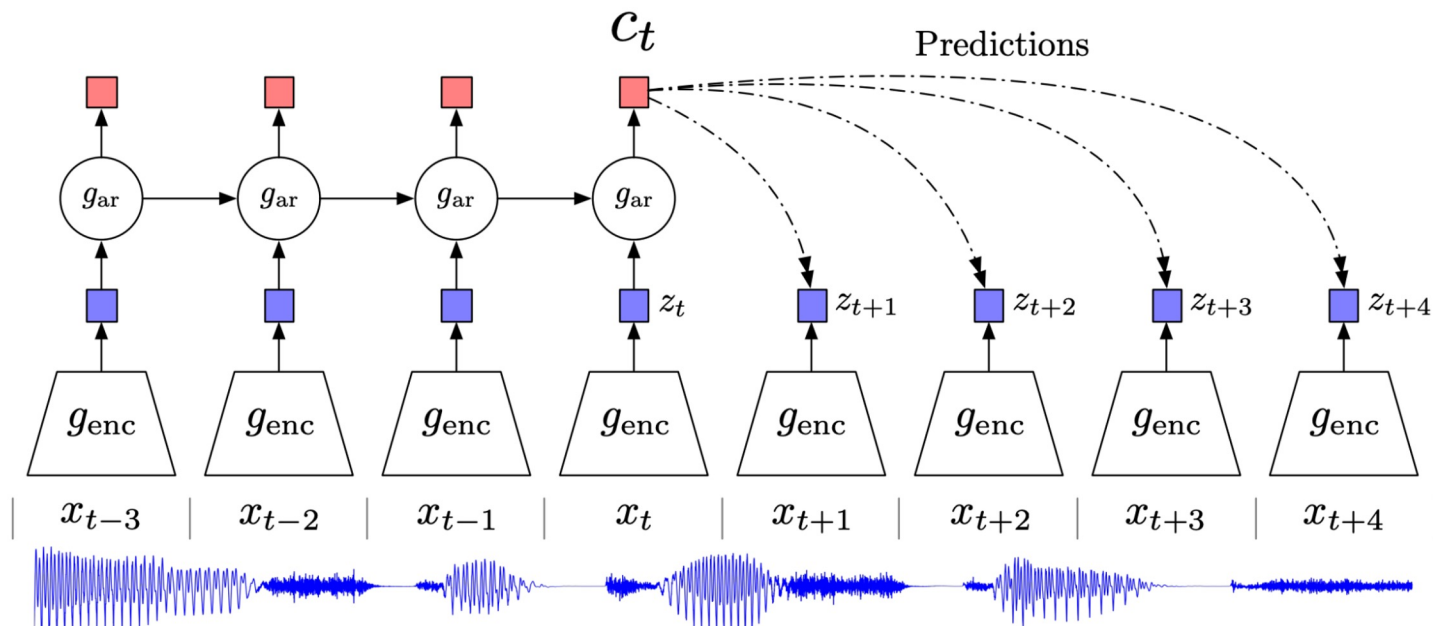

Source: [van den Oord et al., 2018](#),

CPC example: modeling audio sequences

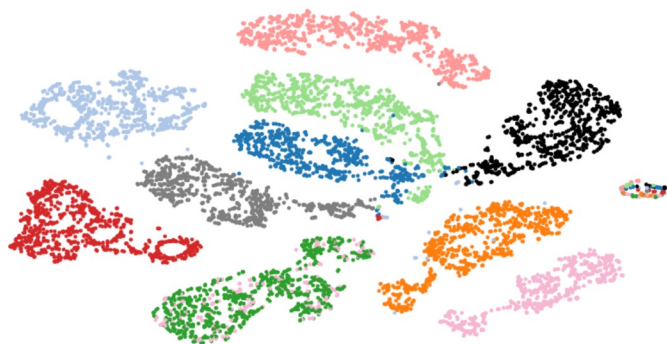

Figure 2: t-SNE visualization of audio (speech) representations for a subset of 10 speakers (out of 251). Every color represents a different speaker.

Method	ACC
Phone classification	
Random initialization	27.6
MFCC features	39.7
CPC	64.6
Supervised	74.6
Speaker classification	
Random initialization	1.87
MFCC features	17.6
CPC	97.4
Supervised	98.5

Linear classification on trained representations (LibriSpeech dataset)

Source: [van den Oord et al., 2018](#),

CPC example: modeling visual context

Idea: split image into patches, model rows of patches from top to bottom as a sequence. I.e., use top rows as context to predict bottom rows.

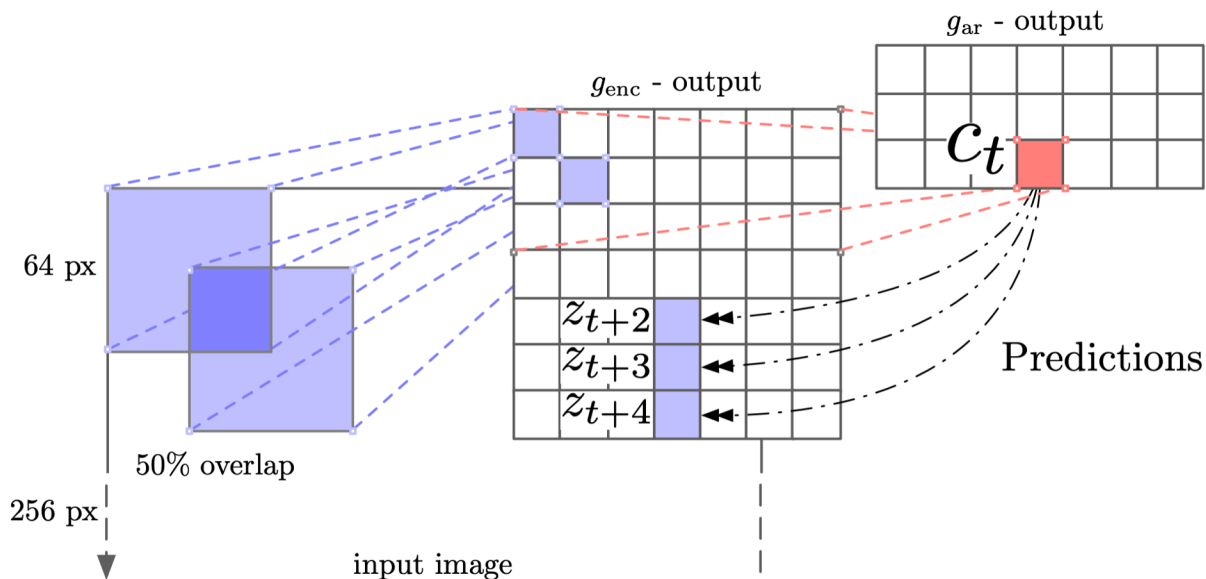

Source: [van den Oord et al., 2018](#),

CPC example: modeling visual context

Method	Top-1 ACC
Using AlexNet conv5	
Video [28]	29.8
Relative Position [11]	30.4
BiGan [35]	34.8
Colorization [10]	35.2
Jigsaw [29] *	38.1
Using ResNet-V2	
Motion Segmentation [36]	27.6
Exemplar [36]	31.5
Relative Position [36]	36.2
Colorization [36]	39.6
CPC	48.7

Table 3: ImageNet top-1 unsupervised classification results. *Jigsaw is not directly comparable to the other AlexNet results because of architectural differences.

- Compares favorably with other pretext task-based self-supervised learning method.
- Doesn't do as well compared to newer instance-based contrastive learning methods on image feature learning.

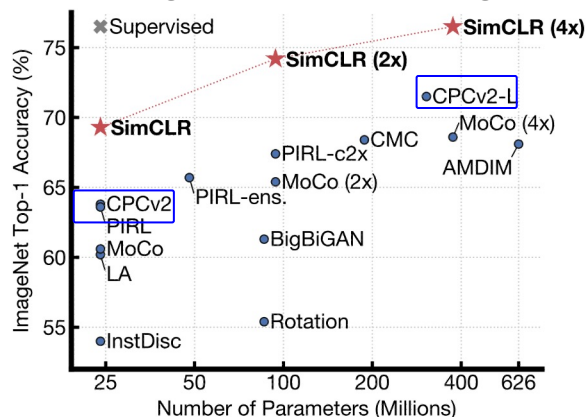

Source: [van den Oord et al., 2018](#),

Summary: Contrastive Representation Learning

A general formulation for contrastive learning:

$$\text{score}(f(x), f(x^+)) \gg \text{score}(f(x), f(x^-))$$

InfoNCE loss: N-way classification among positive and negative samples

$$L = -\mathbb{E}_X \left[\log \frac{\exp(s(f(x), f(x^+)))}{\exp(s(f(x), f(x^+))) + \sum_{j=1}^{N-1} \exp(s(f(x), f(x_j^-)))} \right]$$

Commonly known as the InfoNCE loss ([van den Oord et al., 2018](#))

A lower bound on the mutual information between $f(x)$ and $f(x^+)$

$$MI[f(x), f(x^+)] - \log(N) \geq -L$$

Summary: Contrastive Representation Learning

SimCLR: a simple framework for contrastive representation learning

- Key ideas: non-linear projection head to allow flexible representation learning
- Simple to implement, effective in learning visual representation
- Requires large training batch size to be effective; large memory footprint

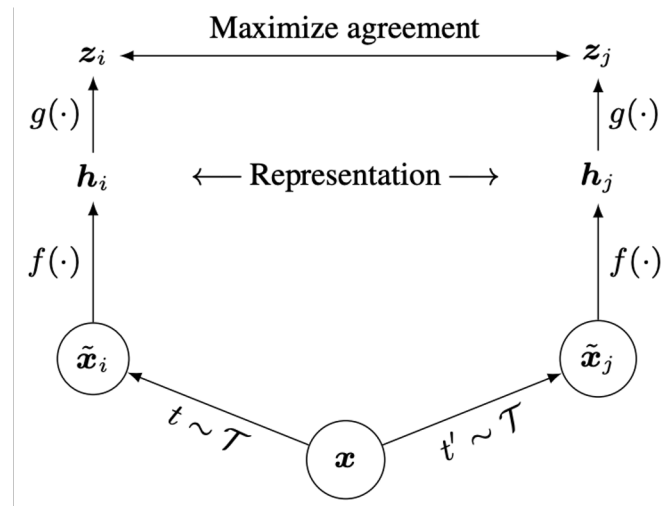

Summary: Contrastive Representation Learning

MoCo (v1, v2): contrastive learning using momentum sample encoder

- Decouples negative sample size from minibatch size; allows large batch training without TPU
- MoCo-v2 combines the key ideas from SimCLR, i.e., nonlinear projection head, strong data augmentation, with momentum contrastive learning

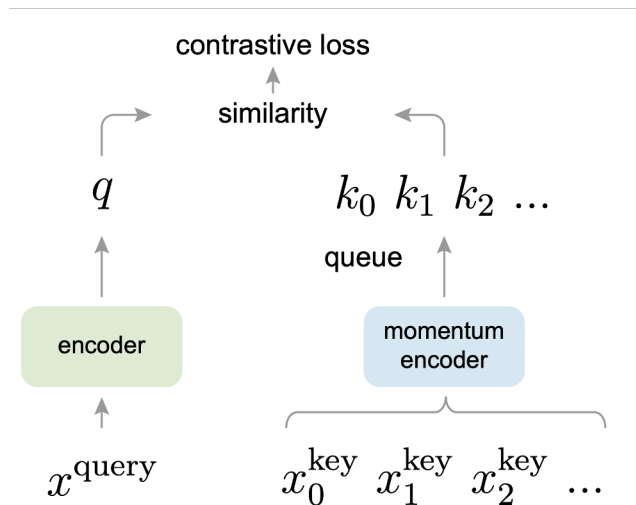

Summary: Contrastive Representation Learning

CPC: sequence-level contrastive learning

- Contrast “right” sequence with “wrong” sequence.
- InfoNCE loss with a time-dependent score function.
- Can be applied to a variety of learning problems, but not as effective in learning image representations compared to instance-level methods.

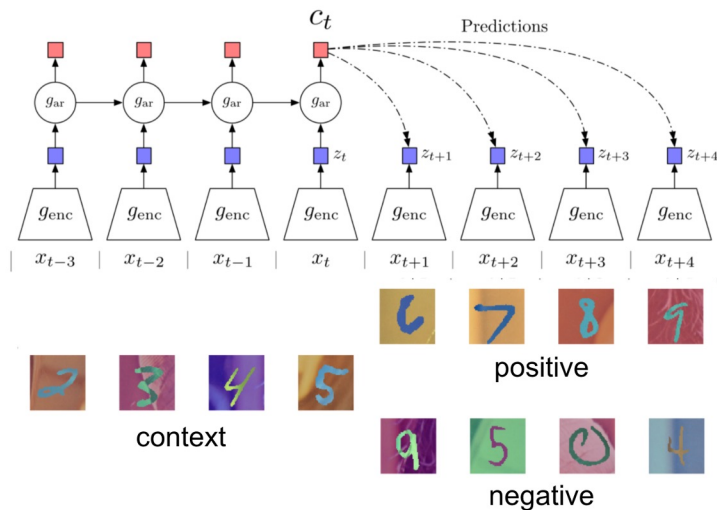

Other examples: MoCo v3

An Empirical Study of Training Self-Supervised Vision Transformers

“This paper does not describe a novel method.”

Xinlei Chen* Saining Xie* Kaiming He
Facebook AI Research (FAIR)

Code: <https://github.com/facebookresearch/moco-v3>

Abstract

This paper does not describe a novel method. Instead, it studies a straightforward, incremental, yet must-know baseline given the recent progress in computer vision: self-supervised learning for Vision Transformers (ViT). While the training recipes for standard convolutional networks have been highly mature and robust, the recipes for ViT are yet to be built, especially in the self-supervised scenarios where training becomes more challenging. In this work, we go back to basics and investigate the effects of several fundamental components for training self-supervised ViT. We observe that instability is a major issue that degrades accuracy, and it can be hidden by apparently good results. We reveal that these results are indeed partial failure, and they can be improved when training is made more stable. We benchmark ViT results in MoCo v3 and several other self-supervised frameworks, with ablations in various aspects. We discuss the currently positive evidence as well as challenges and open questions. We hope that this work will provide useful data points and experience for future research.

framework	model	params	acc. (%)
<i>linear probing:</i>			
iGPT [9]	iGPT-L	1362M	69.0
iGPT [9]	iGPT-XL	6801M	72.0
MoCo v3	ViT-B	86M	76.7
MoCo v3	ViT-L	304M	77.6
MoCo v3	ViT-H	632M	78.1
MoCo v3	ViT-BN-H	632M	79.1
MoCo v3	ViT-BN-L/7	304M	81.0
<i>end-to-end fine-tuning:</i>			
masked patch pred. [16]	ViT-B	86M	79.9 [†]
MoCo v3	ViT-B	86M	83.2
MoCo v3	ViT-L	304M	84.1

Table 1. **State-of-the-art Self-supervised Transformers** in ImageNet classification, evaluated by linear probing (top panel) or end-to-end fine-tuning (bottom panel). Both iGPT [9] and masked patch prediction [16] belong to the masked auto-encoding paradigm. MoCo v3 is a contrastive learning method that compares two (224×224) crops. ViT-B, -L, -H are the Vision Transformers proposed in [16]. ViT-BN is modified with BatchNorm, and “/7” denotes a patch size of 7×7. [†]: pre-trained in JFT-300M.

Chen et al., An Empirical Study of Training Self-Supervised Vision Transformers, FAIR

Other examples: Masked Autoencoder

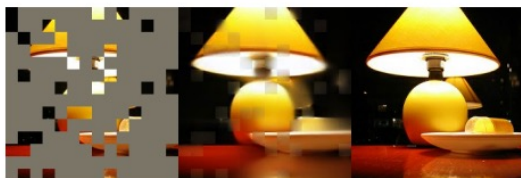
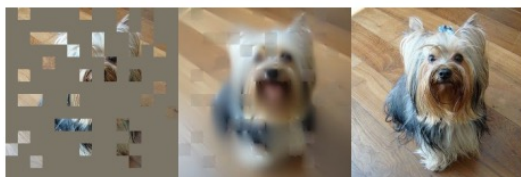
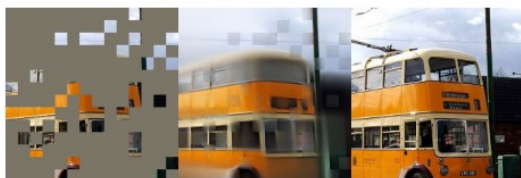

method	pre-train data	ViT-B	ViT-L	ViT-H	ViT-H ₄₄₈
scratch, our impl.	-	82.3	82.6	83.1	-
DINO [5]	IN1K	82.8	-	-	-
MoCo v3 [9]	IN1K	83.2	84.1	-	-
BEiT [2]	IN1K+DALLE	83.2	85.2	-	-
MAE	IN1K	<u>83.6</u>	<u>85.9</u>	<u>86.9</u>	87.8

He et al., Masked Autoencoders Are Scalable Vision Learners, FAIR

Other examples: Dense Object Net

Contrastive learning on pixel-wise feature descriptors

(c) *Background Randomization*

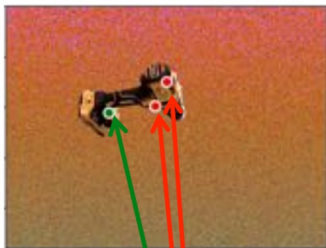

(d) *Cross Object Loss*

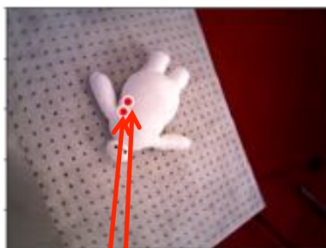

(e) *Direct Multi Object*



(f) *Synthetic Multi Object*

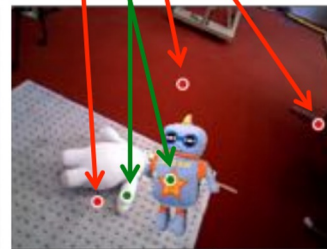
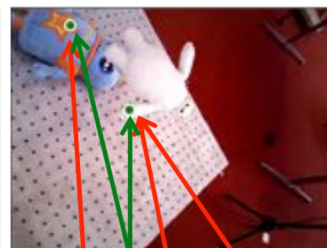

Dense Object Net, Florence et al., 2018

Other examples: Dense Object Net

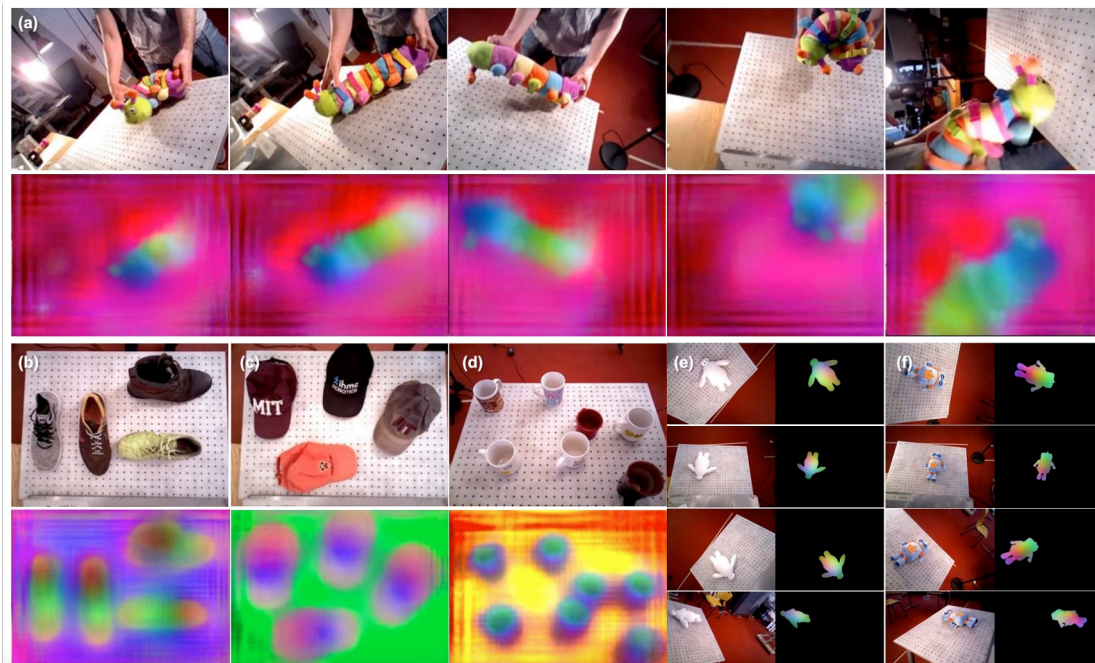

Dense Object Net, Florence et al., 2018

Other examples: Dense Object Net

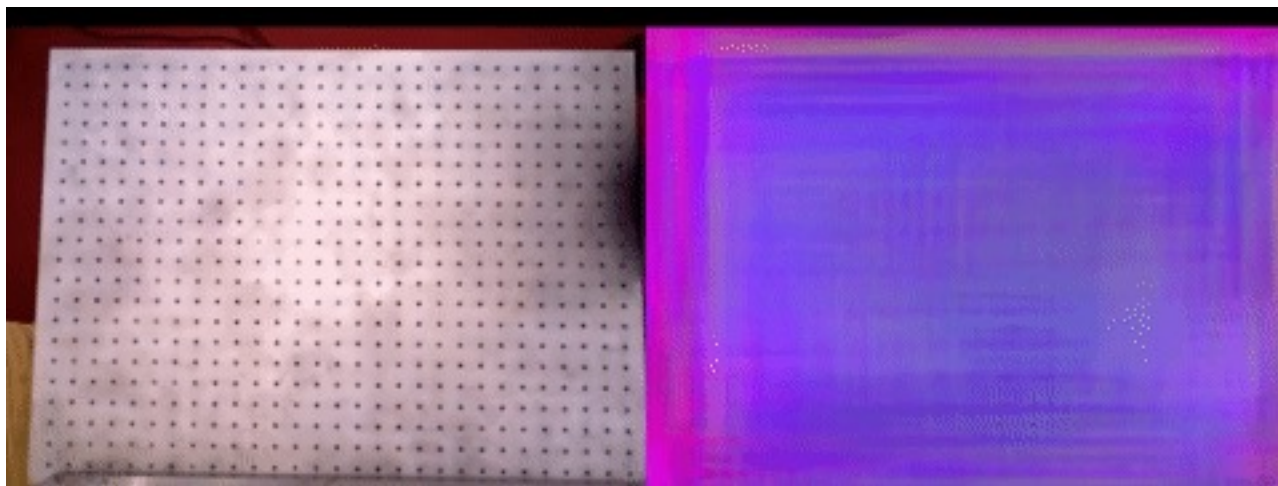

Dense Object Net, Florence et al., 2018

Other examples: DINO

Emerging Properties in Self-Supervised Vision Transformers

Mathilde Caron^{1,2} Hugo Touvron^{1,3} Ishan Misra¹ Hervé Jegou¹
Julien Mairal² Piotr Bojanowski¹ Armand Joulin¹

¹ Facebook AI Research

² Inria*

³ Sorbonne University

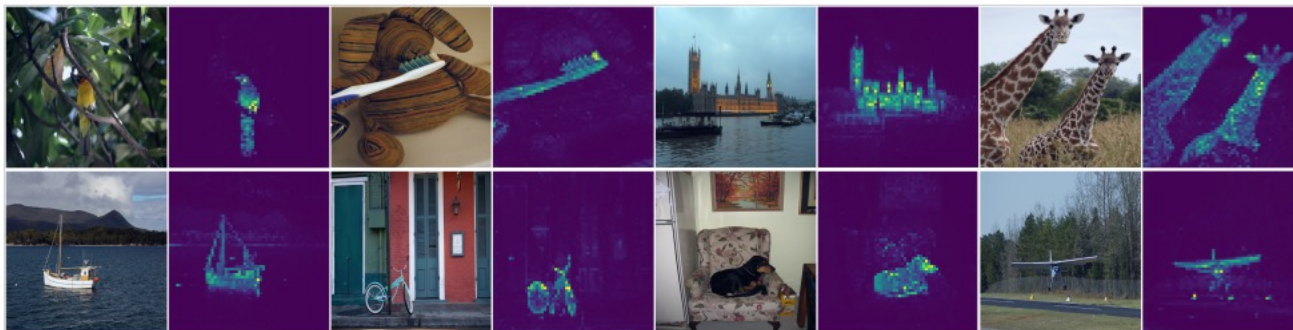

Figure 1: **Self-attention from a Vision Transformer with 8×8 patches trained with no supervision.** We look at the self-attention of the [CLS] token on the heads of the last layer. This token is not attached to any label nor supervision. These maps show that the model automatically learns class-specific features leading to unsupervised object segmentations.

Other examples: DINO v2

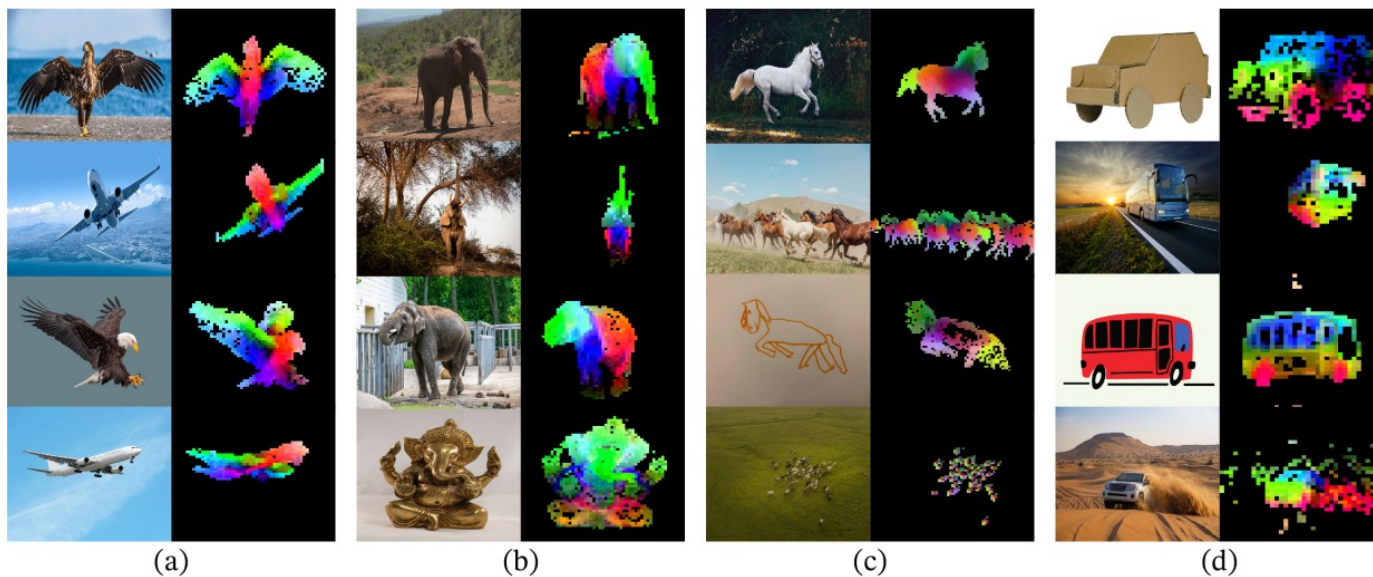
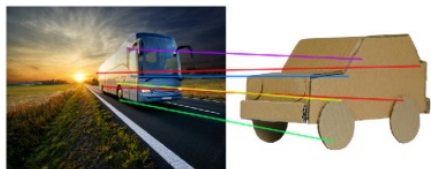
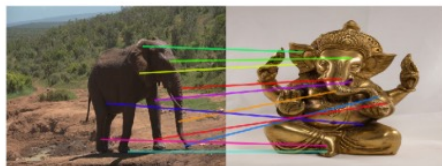

Figure 1: **Visualization of the first PCA components.** We compute a PCA between the patches of the images from the same column (a, b, c and d) and show their first 3 components. Each component is matched to a different color channel. Same parts are matched between related images despite changes of pose, style or even objects. Background is removed by thresholding the first PCA component.

Other examples: DINO v2



(Vehicles)



(Elephants)

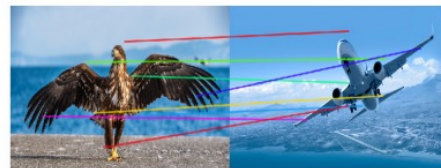
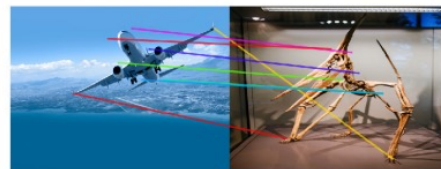

(Birds / Airplanes)

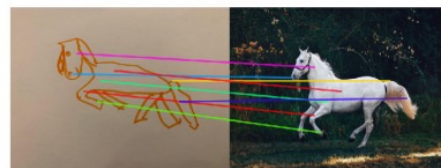

(Drawings / Animals)

Other examples: CLIP

Contrastive learning between image and natural language sentences

1. Contrastive pre-training

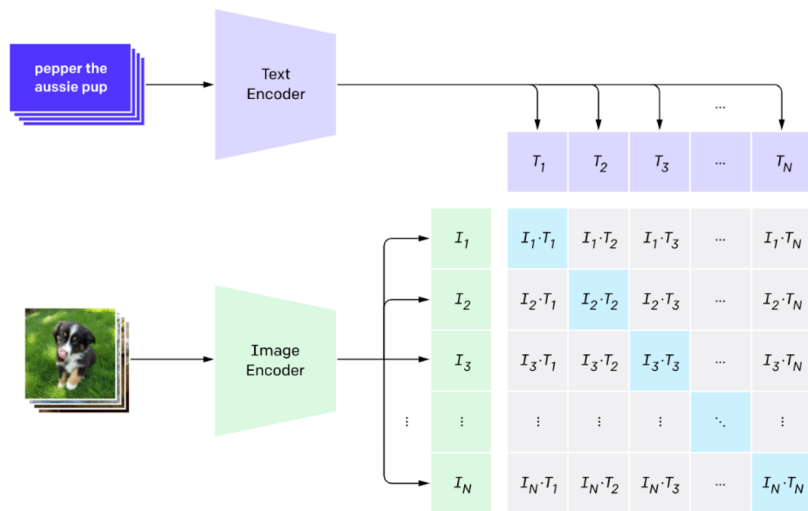

2. Create dataset classifier from label text

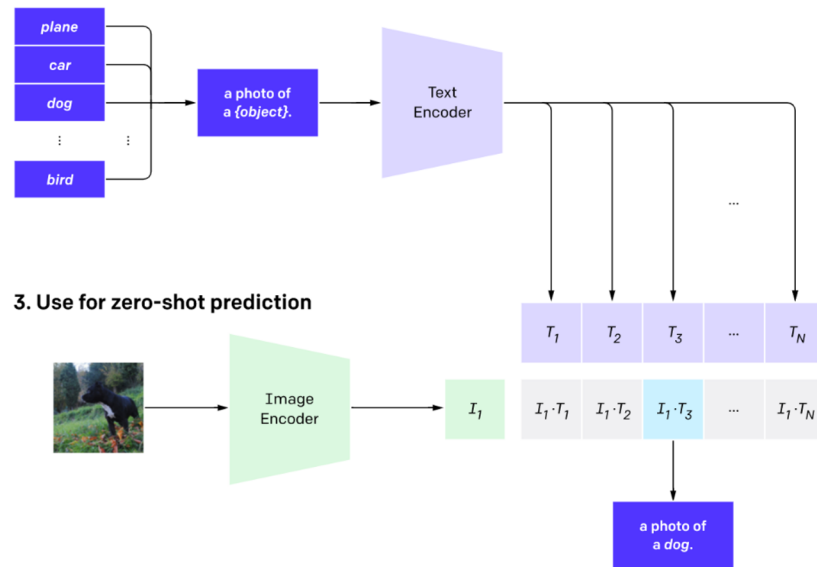

CLIP (Contrastive Language–Image Pre-training) Radford et al., 2021

Next time: Generative Models