

Lecture 5

Epipolar Geometry

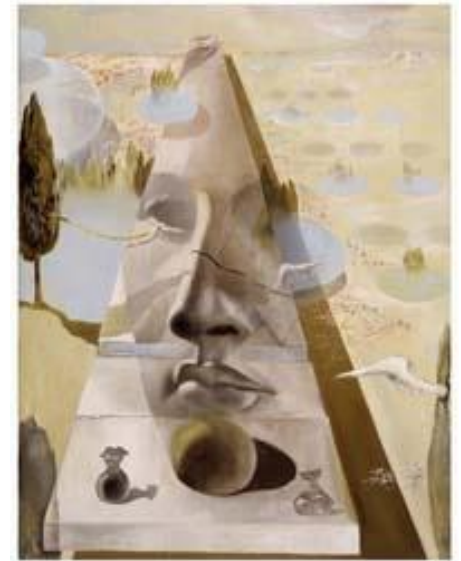

Professor Silvio Savarese

Computational Vision and Geometry Lab

Lecture 5

Epipolar Geometry

- Why is stereo useful?
- Epipolar constraints
- Essential and fundamental matrix
- Estimating F
- Examples

Reading: [AZ] Chapter: 4 “Estimation – 2D perspective transformations”
Chapter: 9 “Epipolar Geometry and the Fundamental Matrix Transformation”
Chapter: 11 “Computation of the Fundamental Matrix F ”
[FP] Chapters: 10 “The geometry of multiple views”

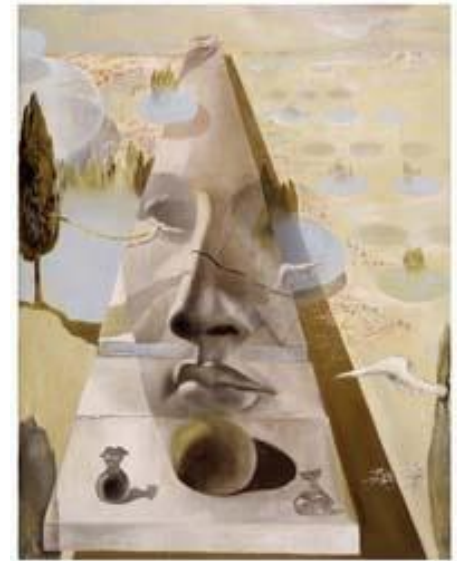

Recovering structure from a single view

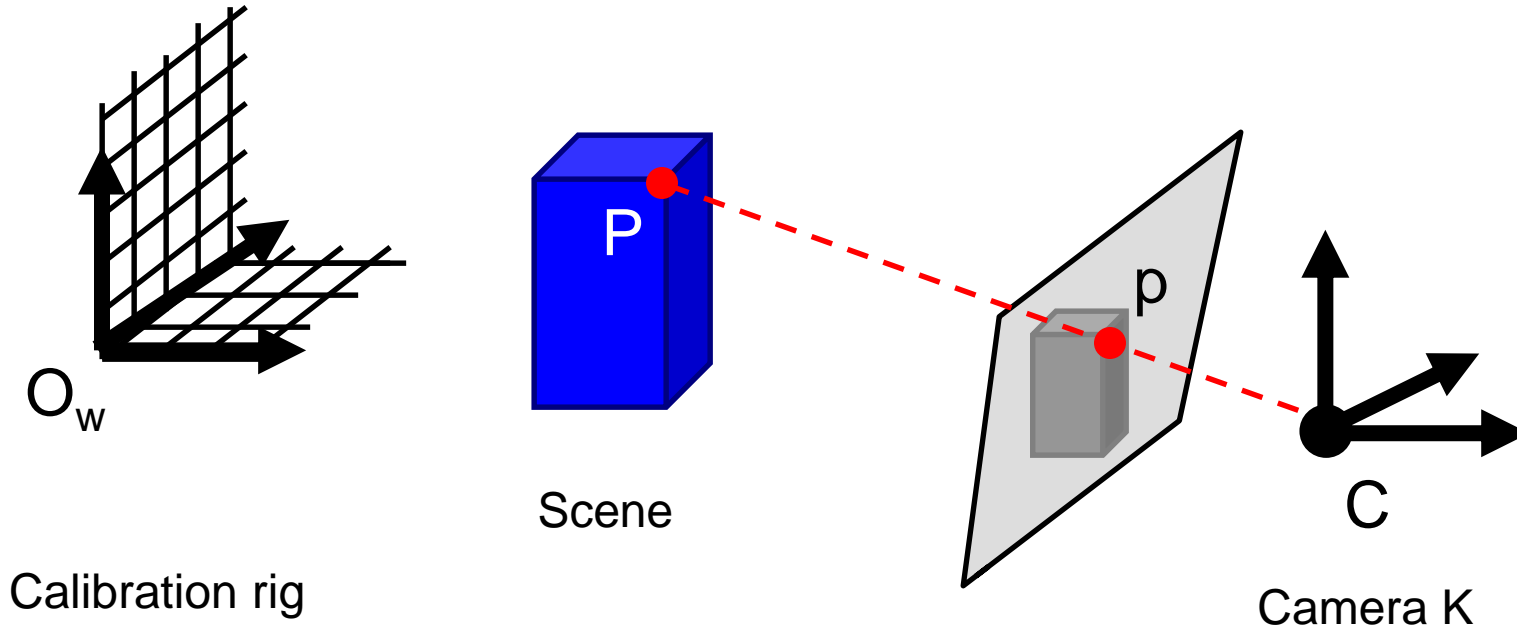

From calibration rig

→ location/pose of the rig, K

From points and lines at infinity
+ orthogonal lines and planes

→ structure of the scene, K

Knowledge about scene (point correspondences, geometry of lines & planes, etc...)

Recovering structure from a single view

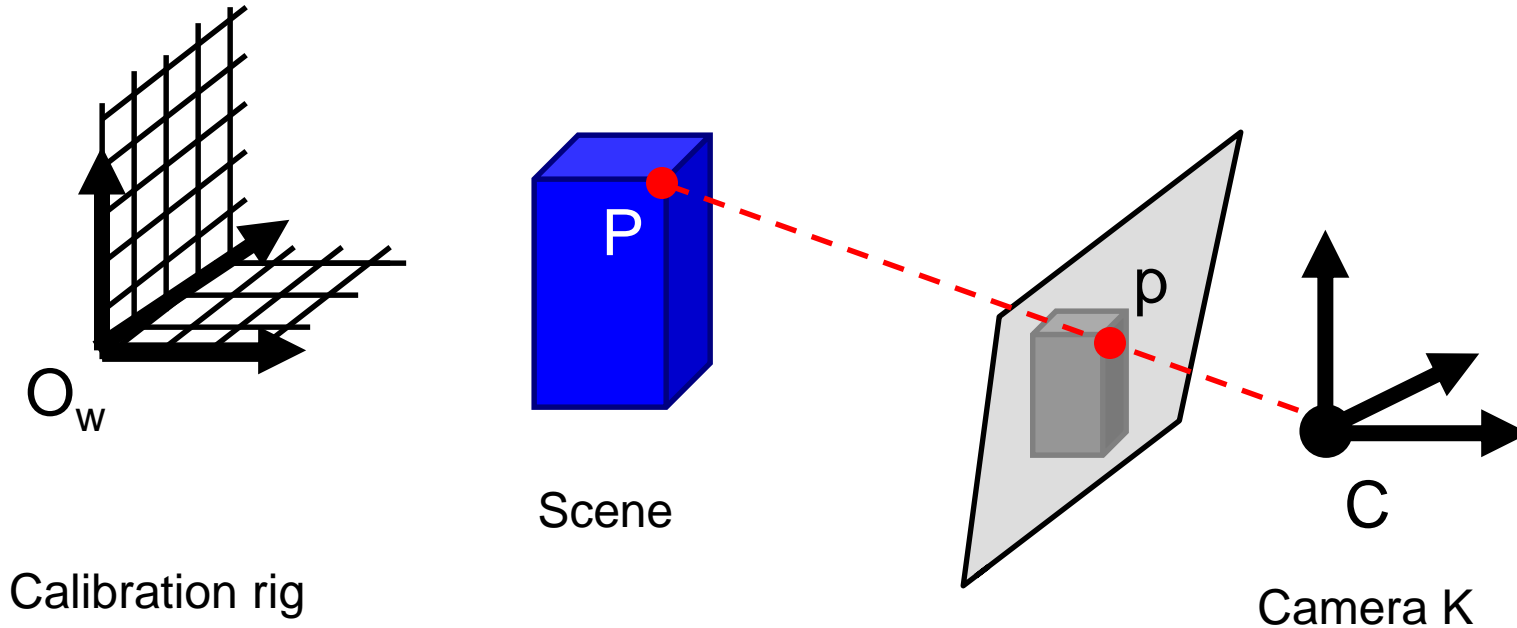

Why is it so difficult?

Intrinsic ambiguity of the mapping from 3D to image (2D)

Recovering structure from a single view

Intrinsic ambiguity of the mapping from 3D to image (2D)



Courtesy slide S. Lazebnik

Two eyes help!

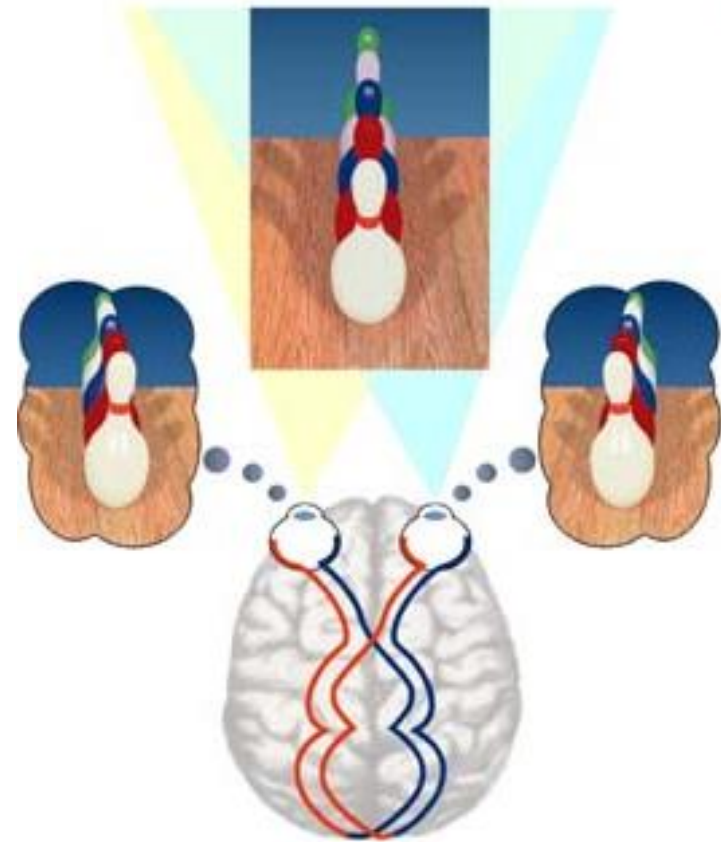

Two eyes help!

$$X = l \times l'$$

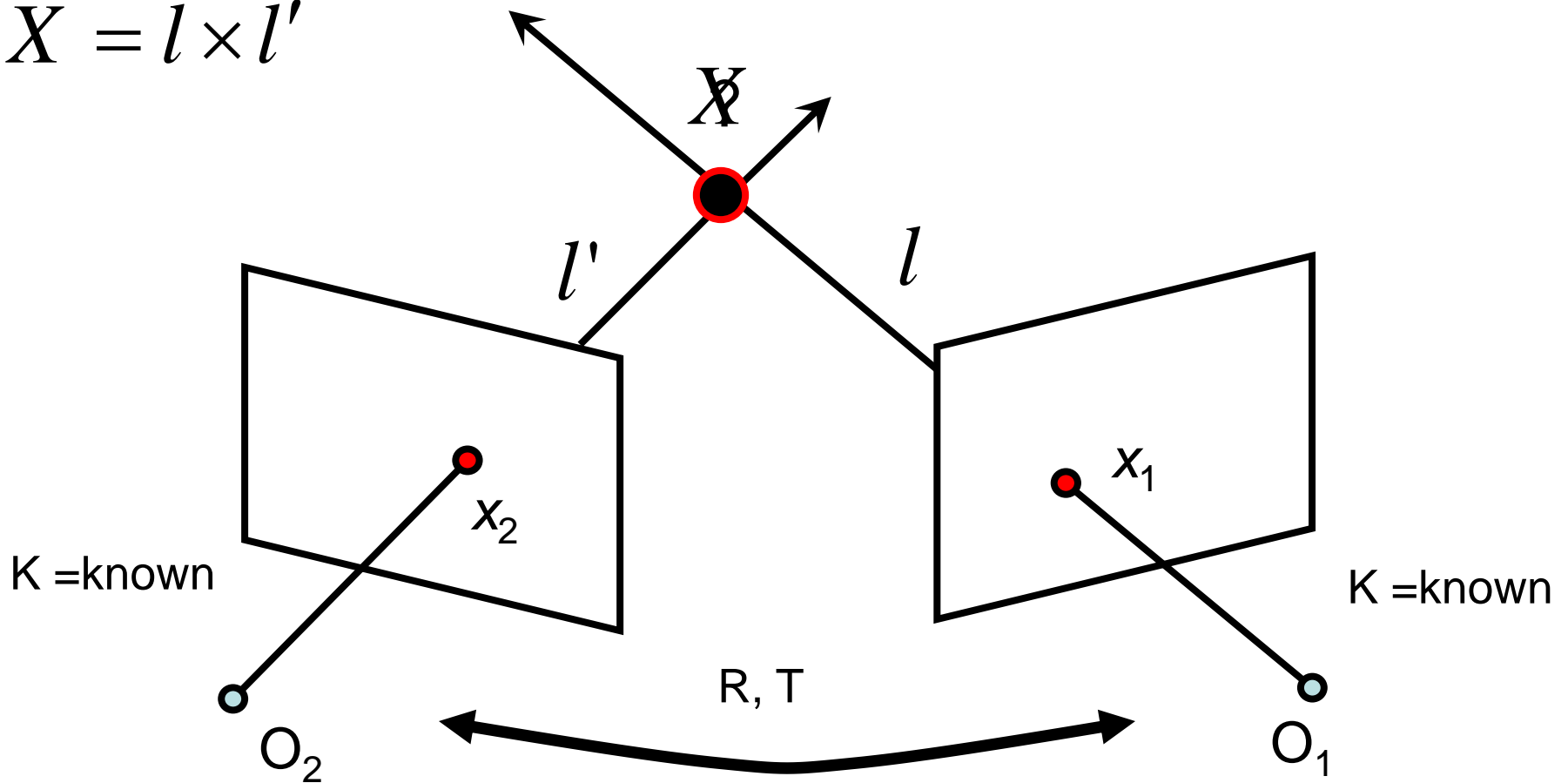

This is called **triangulation**

Triangulation

- Find X that minimizes

$$d^2(x_1, M_1 X) + d^2(x_2, M_2 X)$$

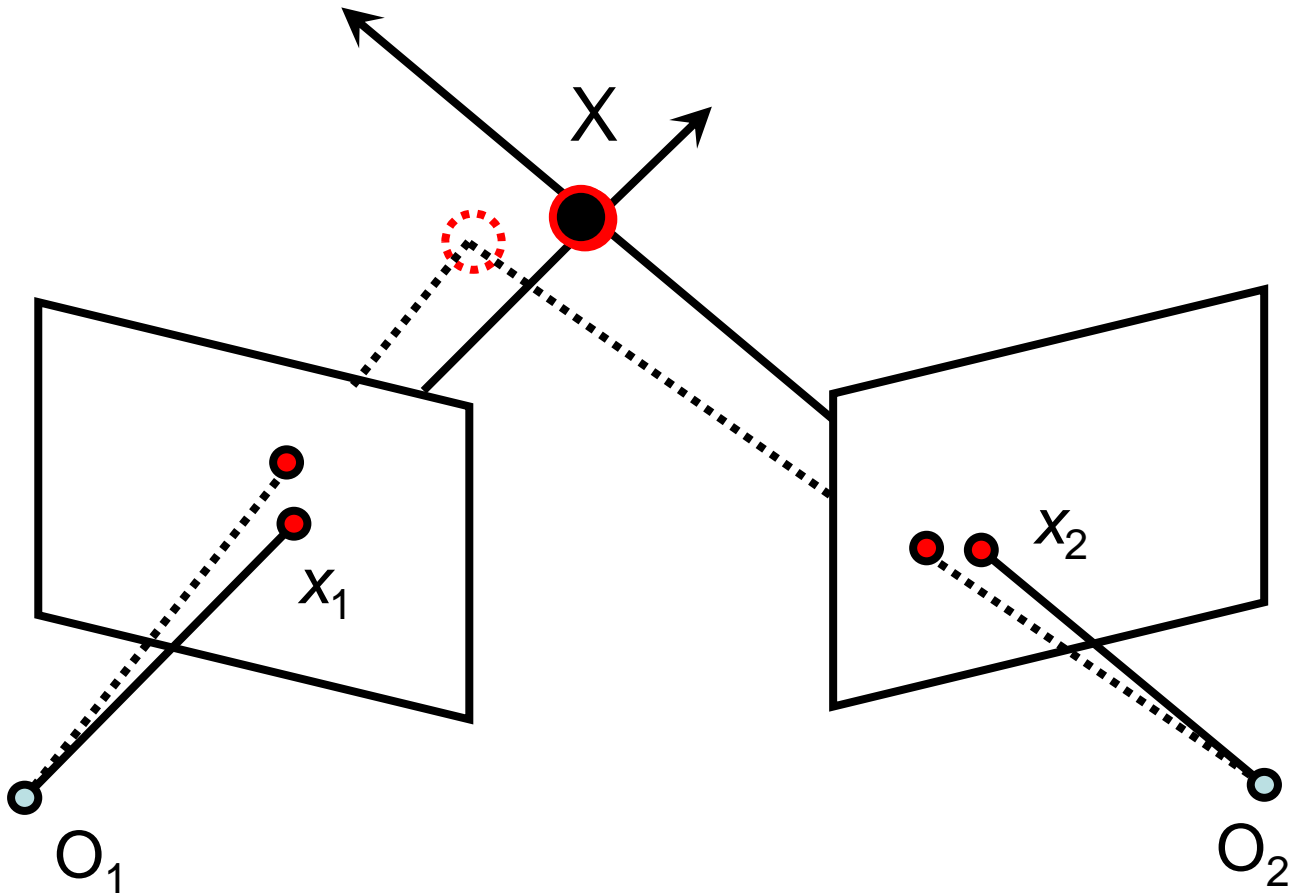

Stereo-view geometry

- **Correspondence:** Given a point in one image, how can I find the corresponding point x' in another one?
- **Camera geometry:** Given corresponding points in two images, find camera matrices, position and pose.
- **Scene geometry:** Find coordinates of 3D point from its projection into 2 or multiple images.

Epipolar geometry

For details see CS131A
Lecture 9

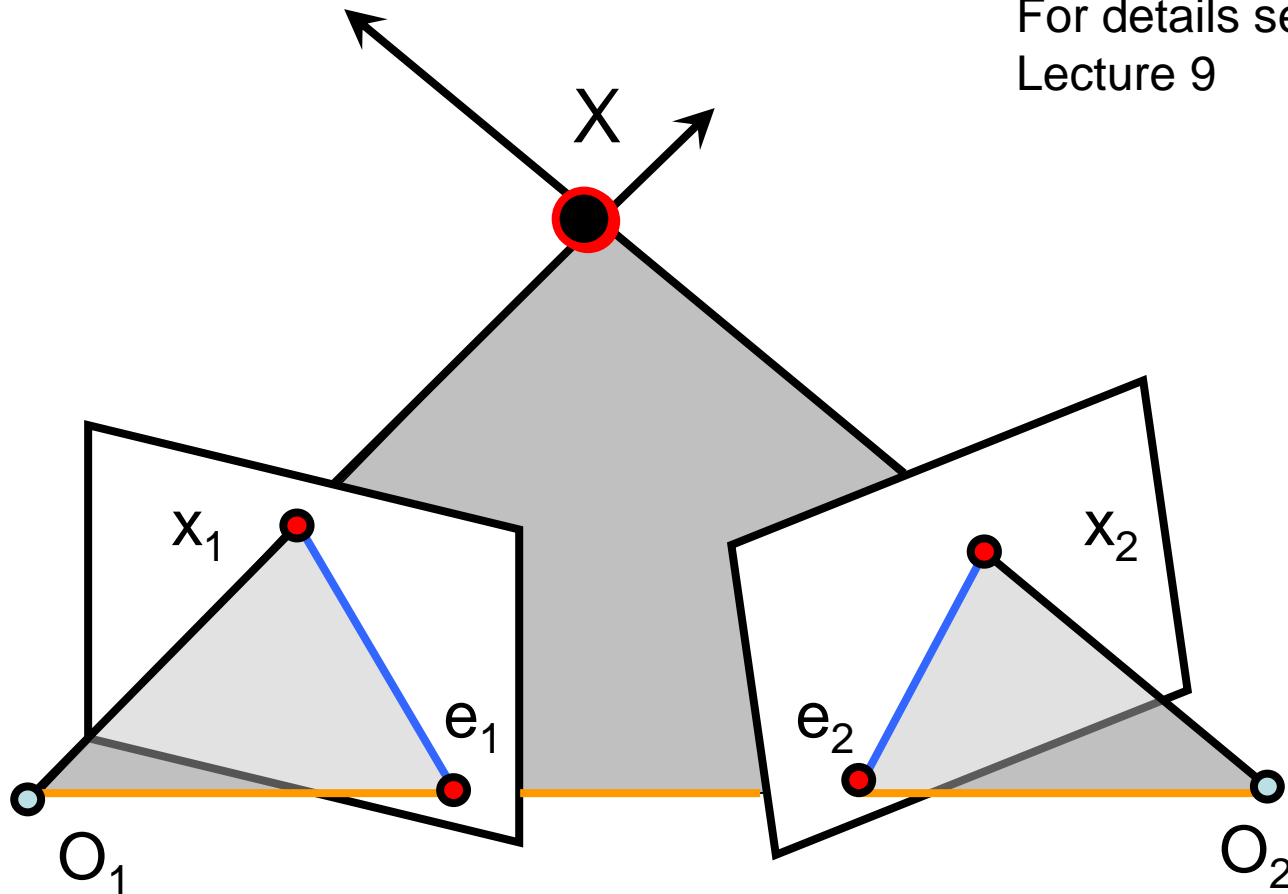

- Epipolar Plane
- Baseline
- Epipolar Lines

- Epipoles e_1, e_2

= intersections of baseline with image planes
= projections of the other camera center

Example: Converging image planes

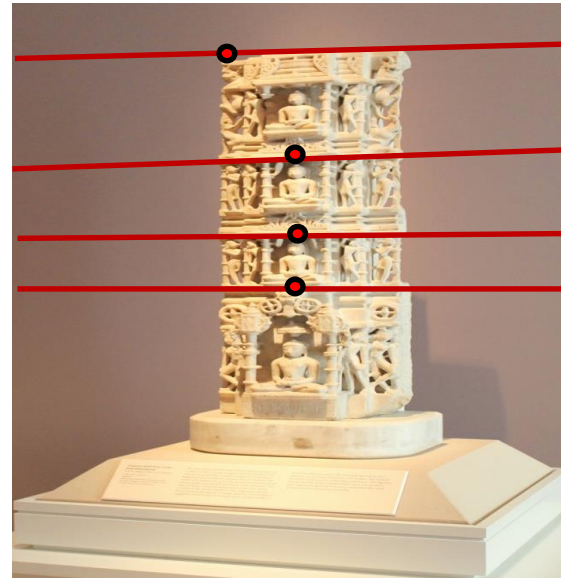
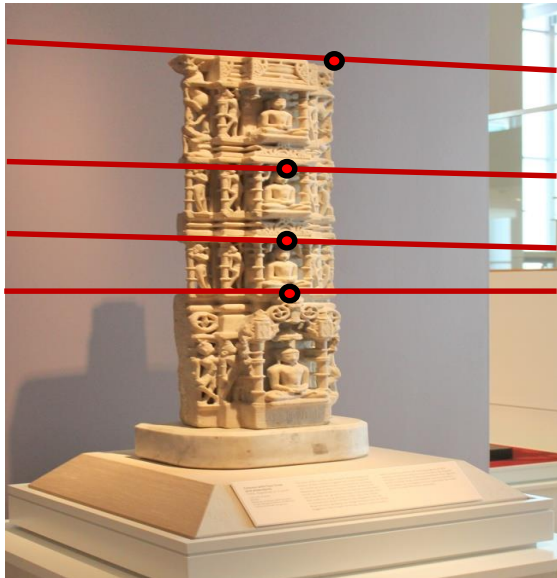
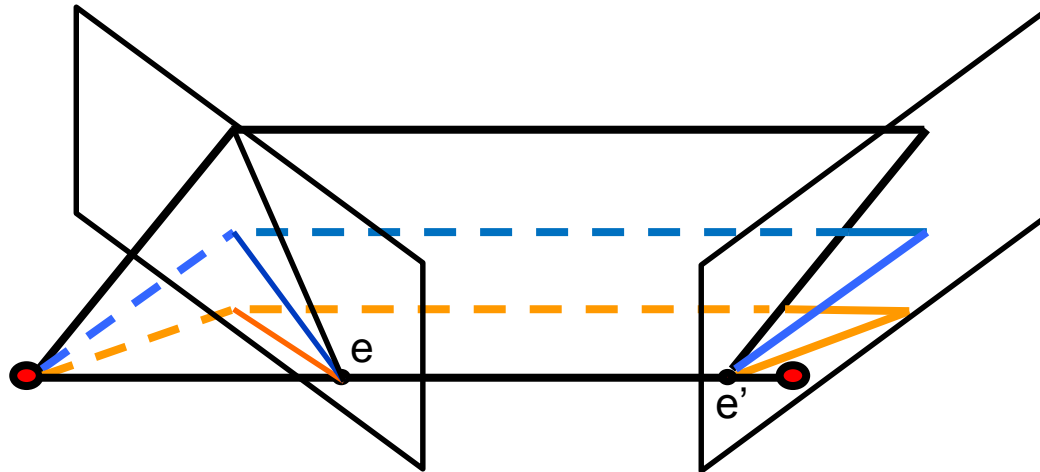

Example: Parallel image planes

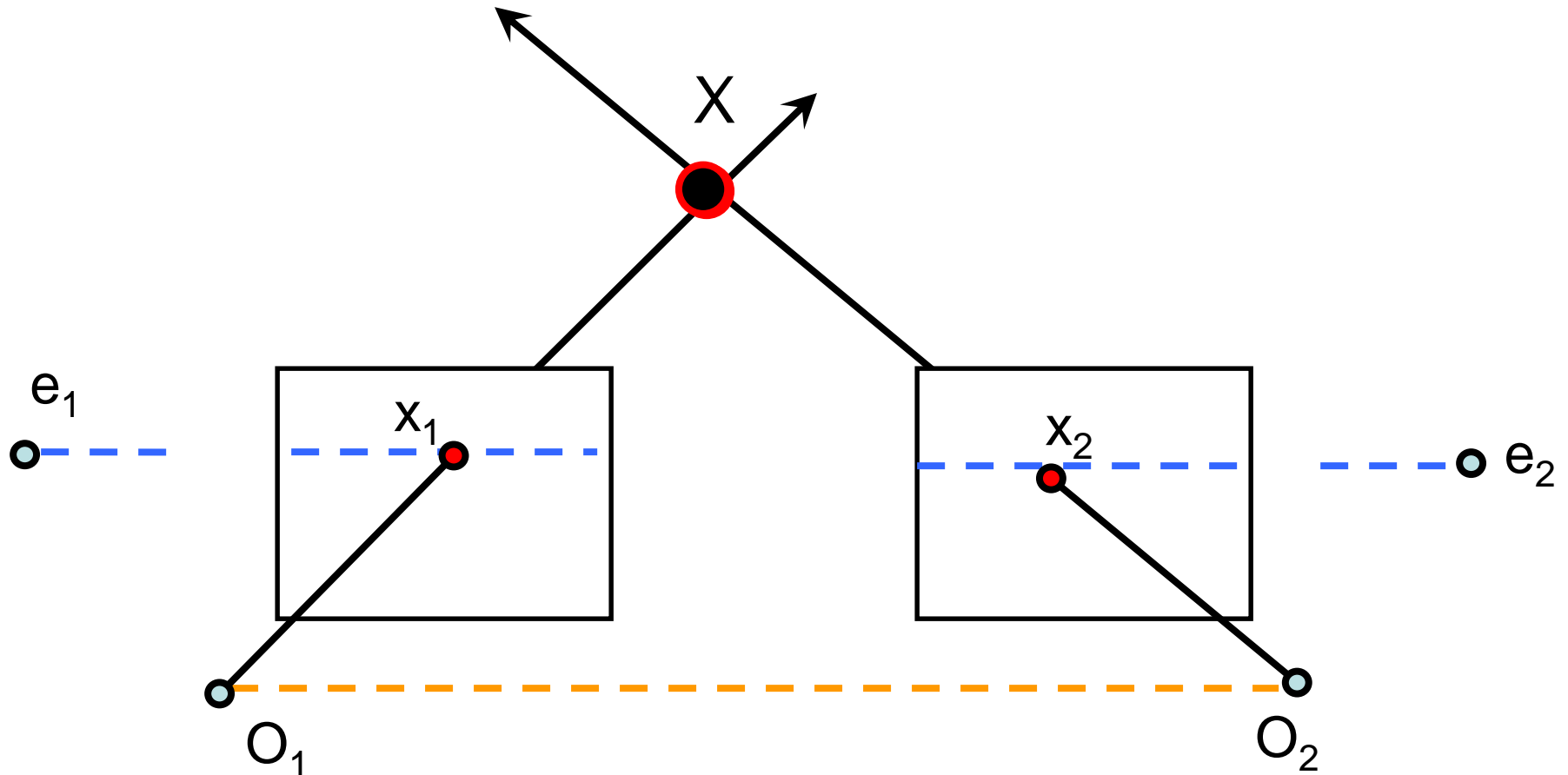

- Baseline intersects the image plane at infinity
- Epipoles are at infinity
- Epipolar lines are parallel to x axis

Example: Parallel Image Planes

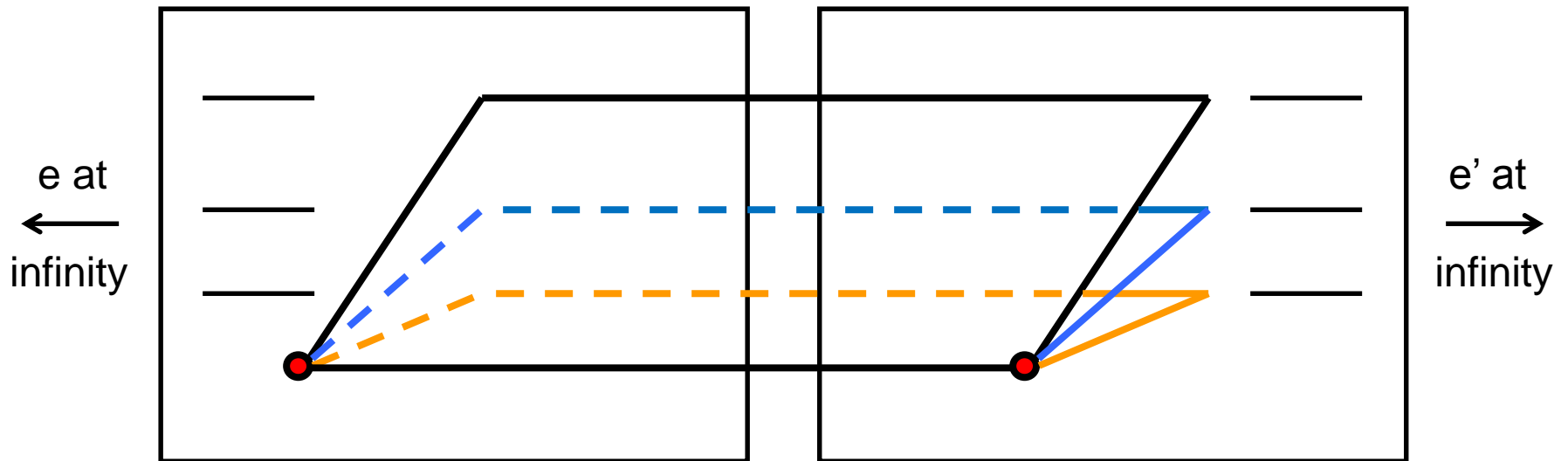

Example: Forward translation

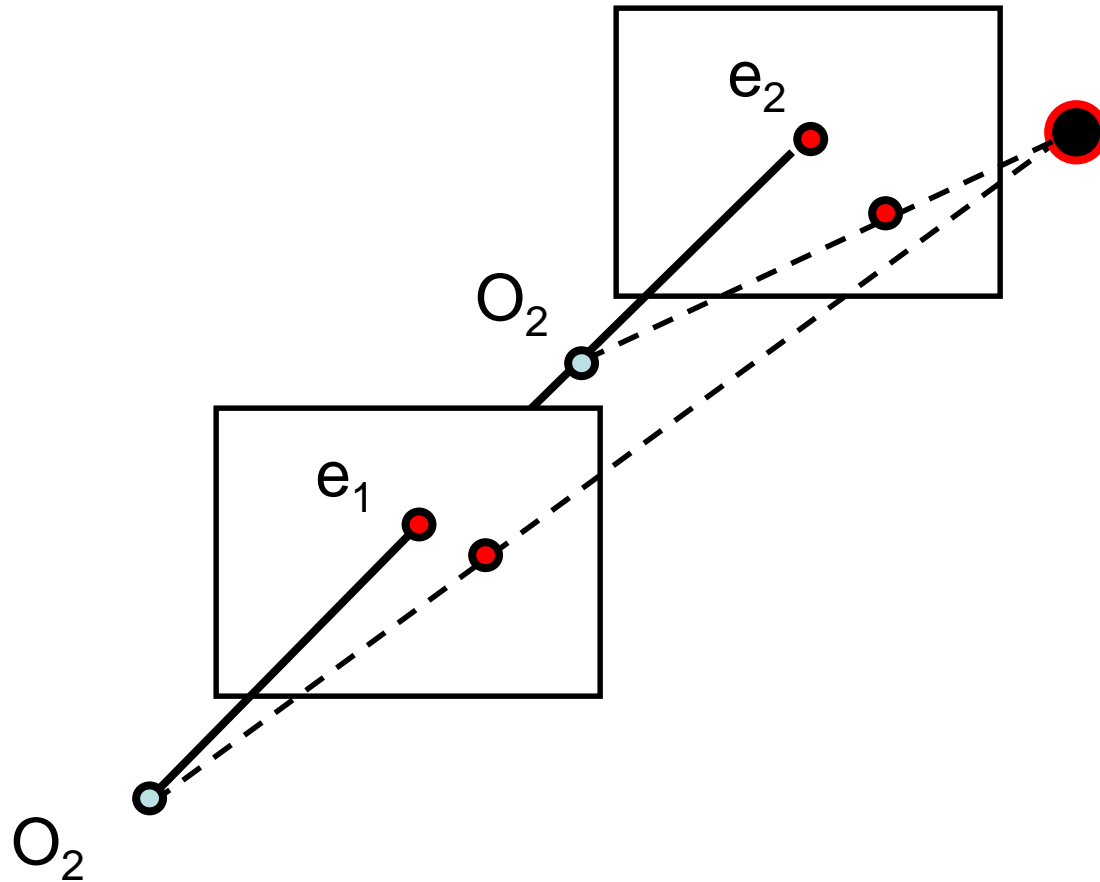

- The epipoles have same position in both images
- Epipole called FOE (focus of expansion)

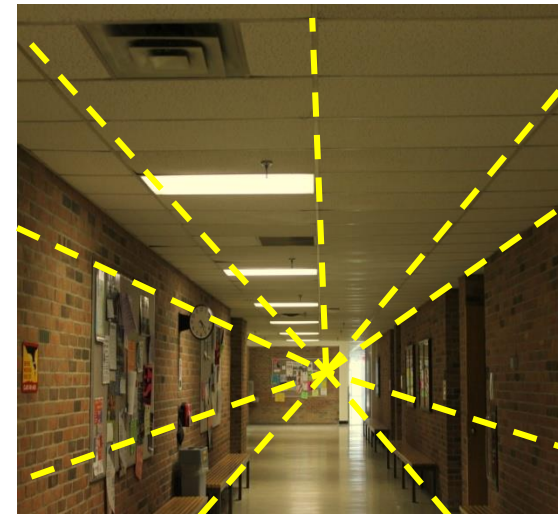
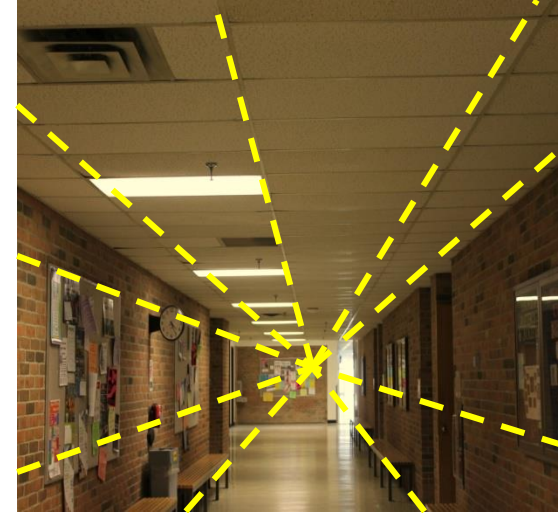

Epipolar Constraint

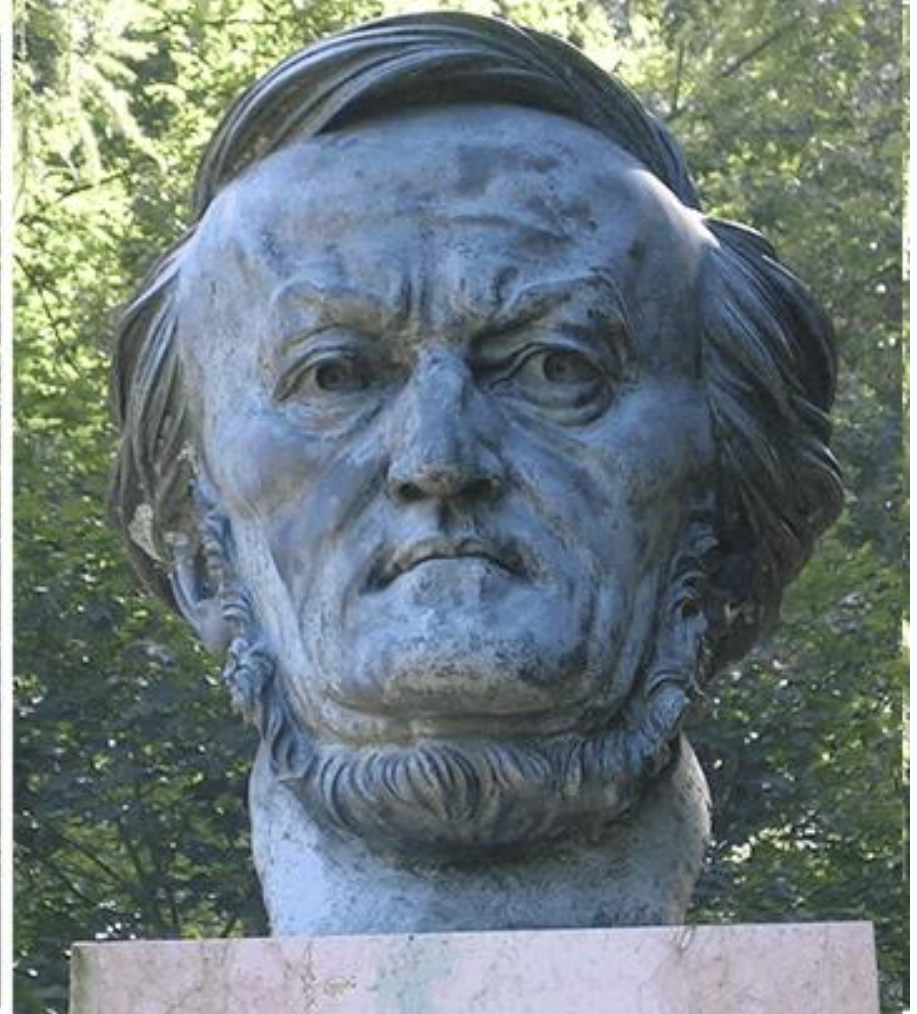

- Two views of the same object
- Suppose I know the camera positions and camera matrices
- Given a point on left image, how can I find the corresponding point on right image?

Epipolar geometry

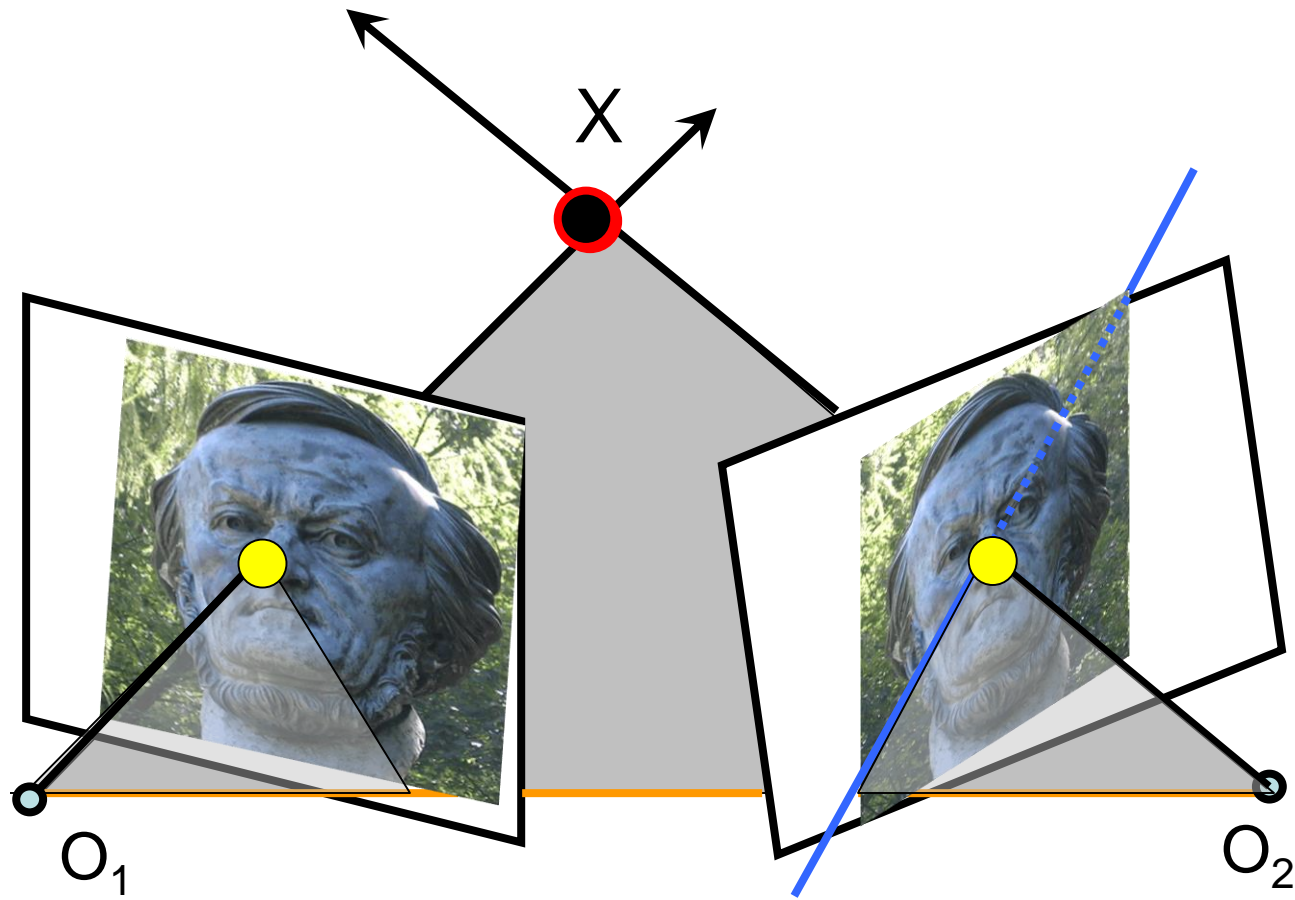

Epipolar Constraint

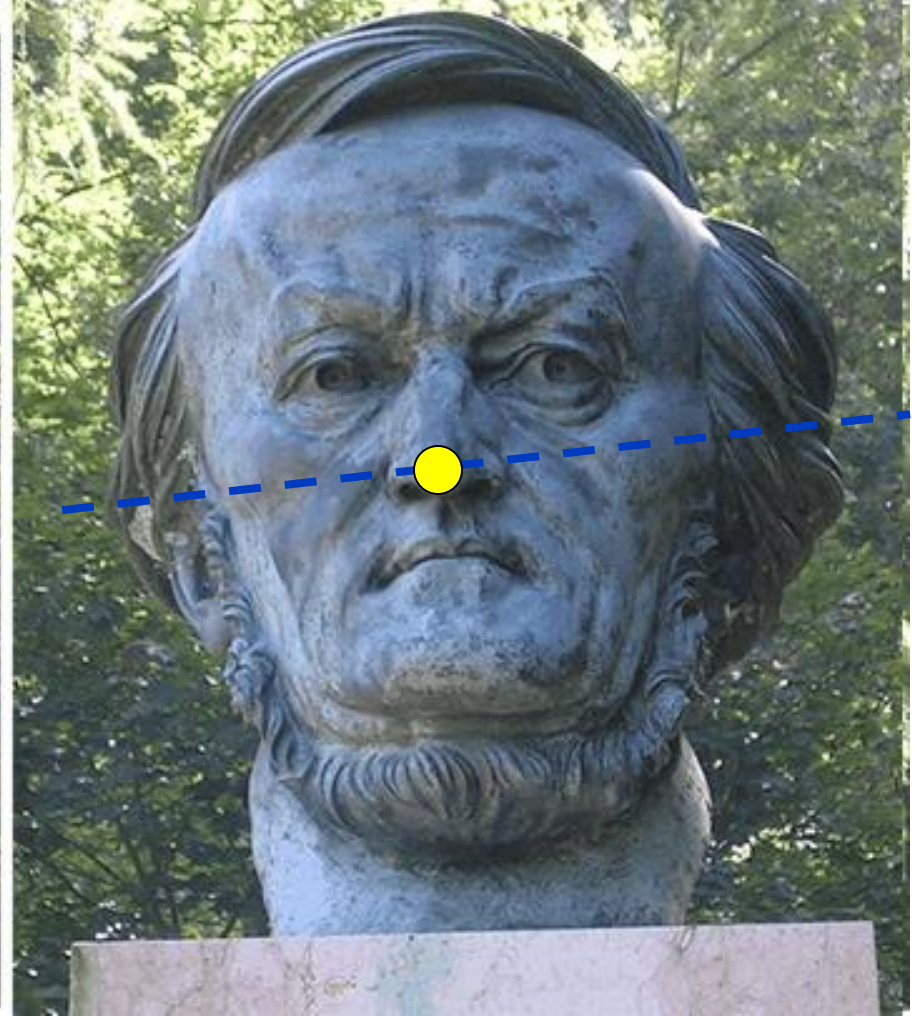

- Two views of the same object
- Suppose I know the camera positions and camera matrices
- Given a point on left image, how can I find the corresponding point on right image?

Epipolar Constraint

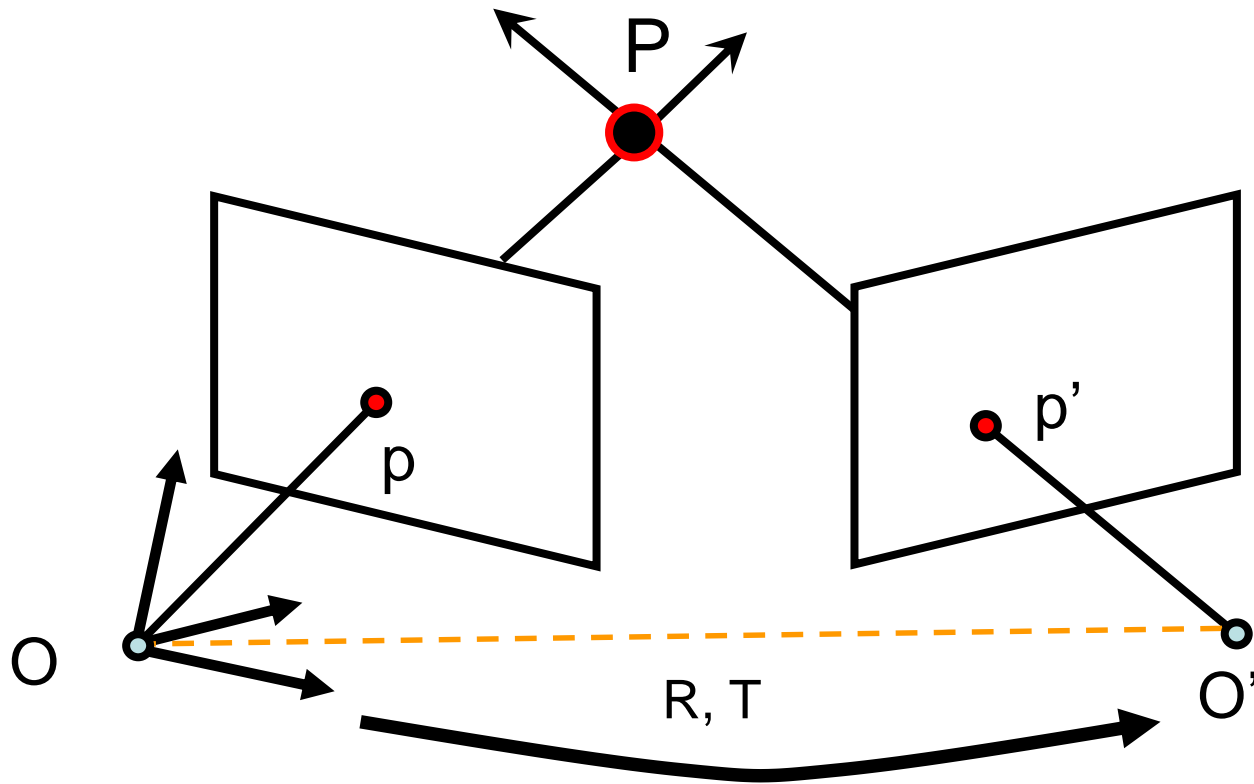

$$M = K \begin{bmatrix} I & 0 \end{bmatrix}$$

$$P \rightarrow M P = \begin{bmatrix} u \\ v \\ 1 \end{bmatrix}$$

$$M' = K \begin{bmatrix} R^T & -R^T T \end{bmatrix}$$

$$P \rightarrow M' P = \begin{bmatrix} u' \\ v' \\ 1 \end{bmatrix}$$

The cameras are related by R, T

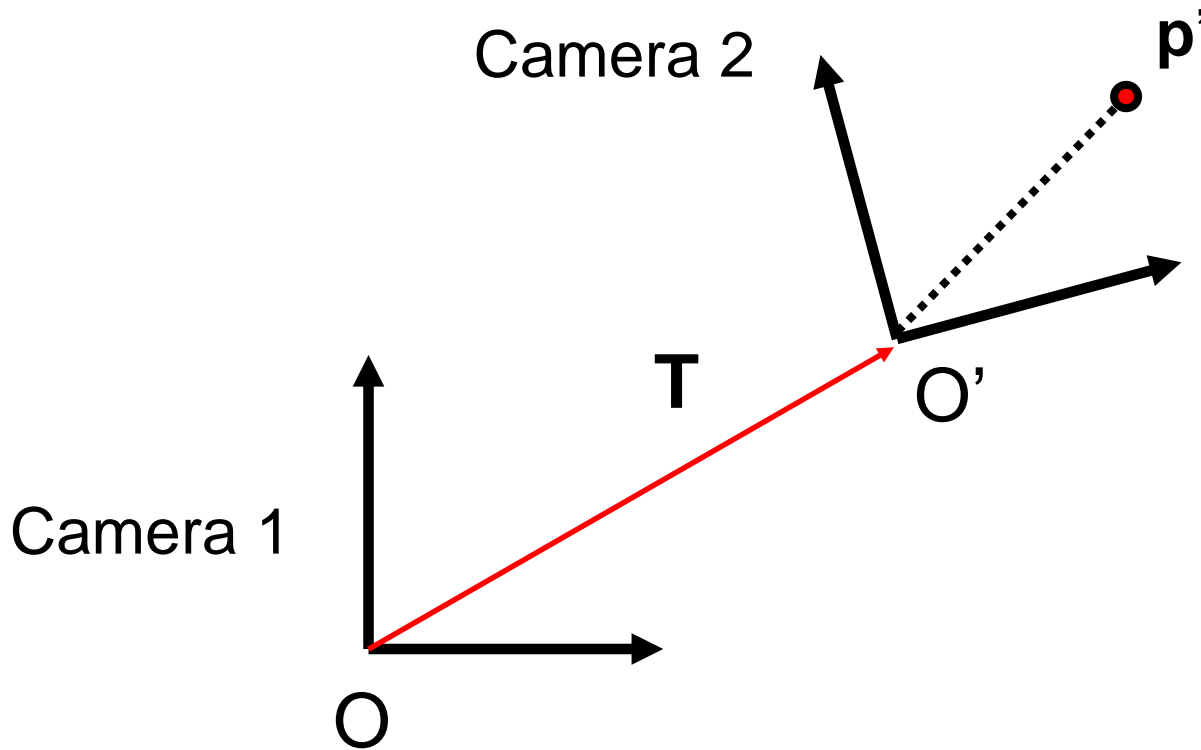

$T = \mathbf{O}'$ in the camera 1 reference system

R is such that a vector \mathbf{p}' in camera 2 is equal to

$R \mathbf{p}'$ in camera 1

Epipolar Constraint

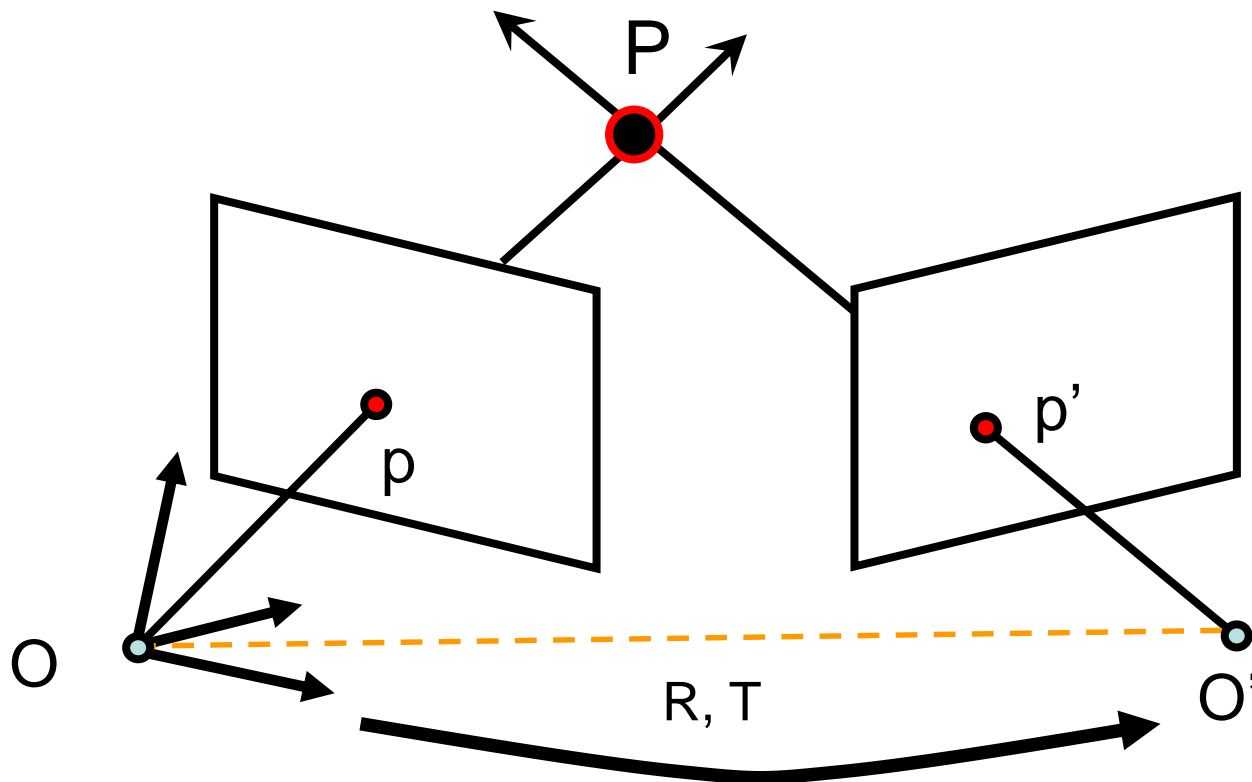

$$M = K \begin{bmatrix} I & 0 \end{bmatrix}$$

K is known
(canonical cameras)

$$M' = K \begin{bmatrix} R^T & -R^T T \end{bmatrix}$$

↓

$$M = \begin{bmatrix} I & 0 \end{bmatrix}$$

$$K = \begin{bmatrix} 1 & 0 & 0 \\ 0 & 1 & 0 \\ 0 & 0 & 1 \end{bmatrix}$$

↓

$$M' = \begin{bmatrix} R^T & -R^T T \end{bmatrix}$$

Epipolar Constraint

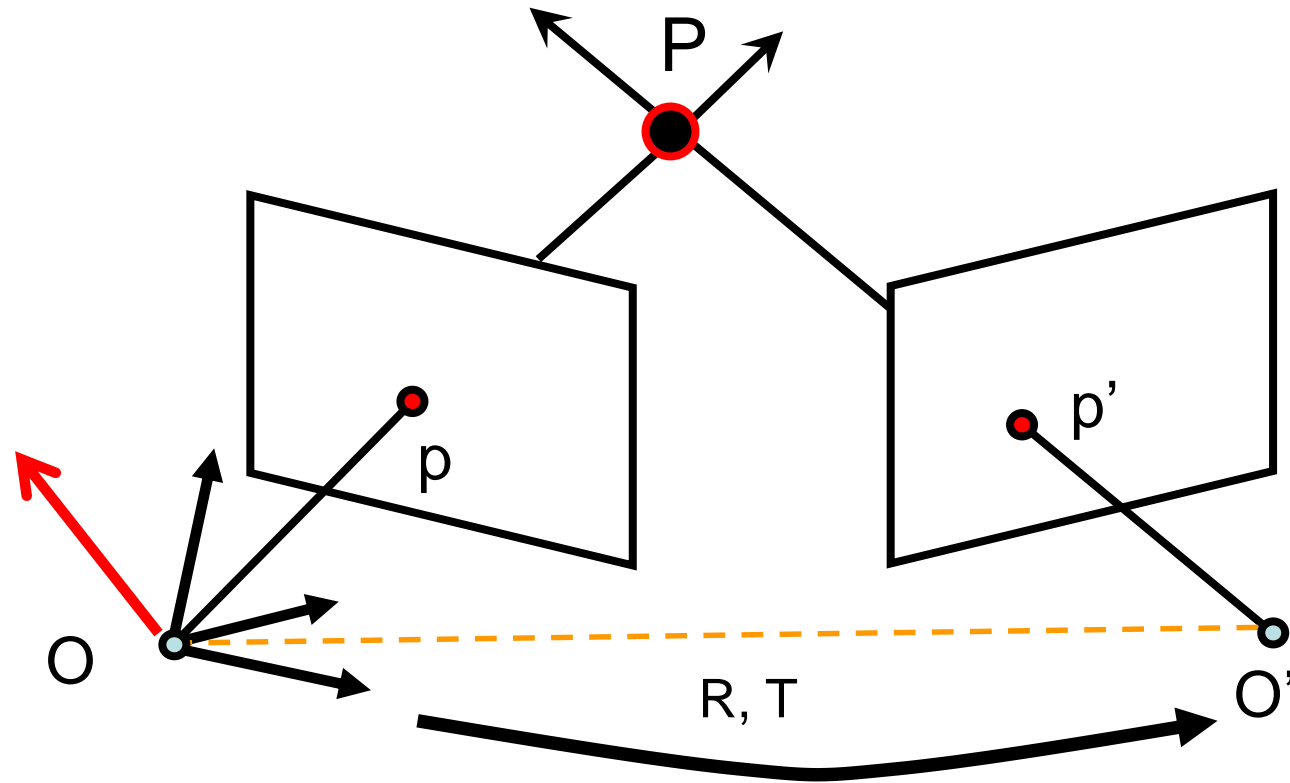

p' in first camera reference system is $= R p'$

$T \times (R p')$ is perpendicular to epipolar plane

$$\rightarrow p^T \cdot [T \times (R p')] = 0$$

Cross product as matrix multiplication

$$\mathbf{a} \times \mathbf{b} = \begin{bmatrix} 0 & -a_z & a_y \\ a_z & 0 & -a_x \\ -a_y & a_x & 0 \end{bmatrix} \begin{bmatrix} b_x \\ b_y \\ b_z \end{bmatrix} = [\mathbf{a}_\times] \mathbf{b}$$

Epipolar Constraint

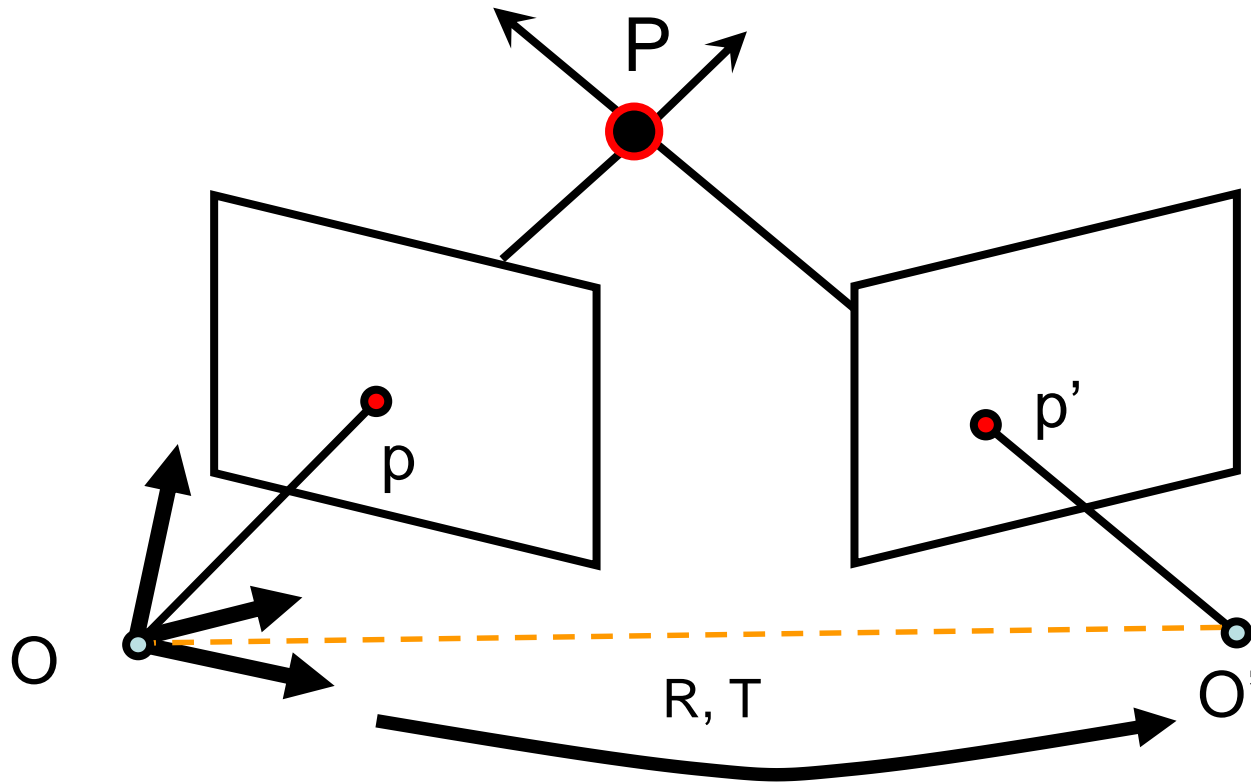

$$p^T \cdot [T \times (R p')] = 0 \rightarrow p^T \cdot [T_{\times}] \cdot R p' = 0$$

E = essential matrix

(Longuet-Higgins, 1981)

Epipolar Constraint

$$p_1^T \cdot E p_2 = 0$$

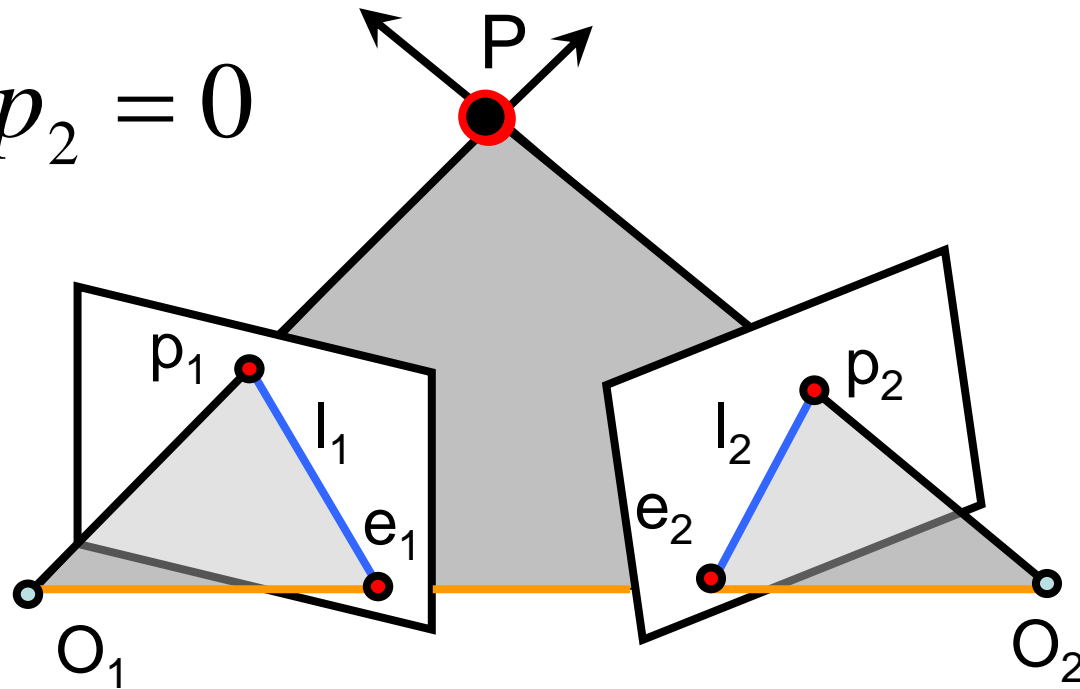

- $E p_2$ is the epipolar line associated with p_2 ($l_1 = E p_2$)
- $E^T p_1$ is the epipolar line associated with p_1 ($l_2 = E^T p_1$)
- $E e_2 = 0$ and $E^T e_1 = 0$
- E is 3x3 matrix; 5 DOF
- E is singular (rank two)

Epipolar Constraint

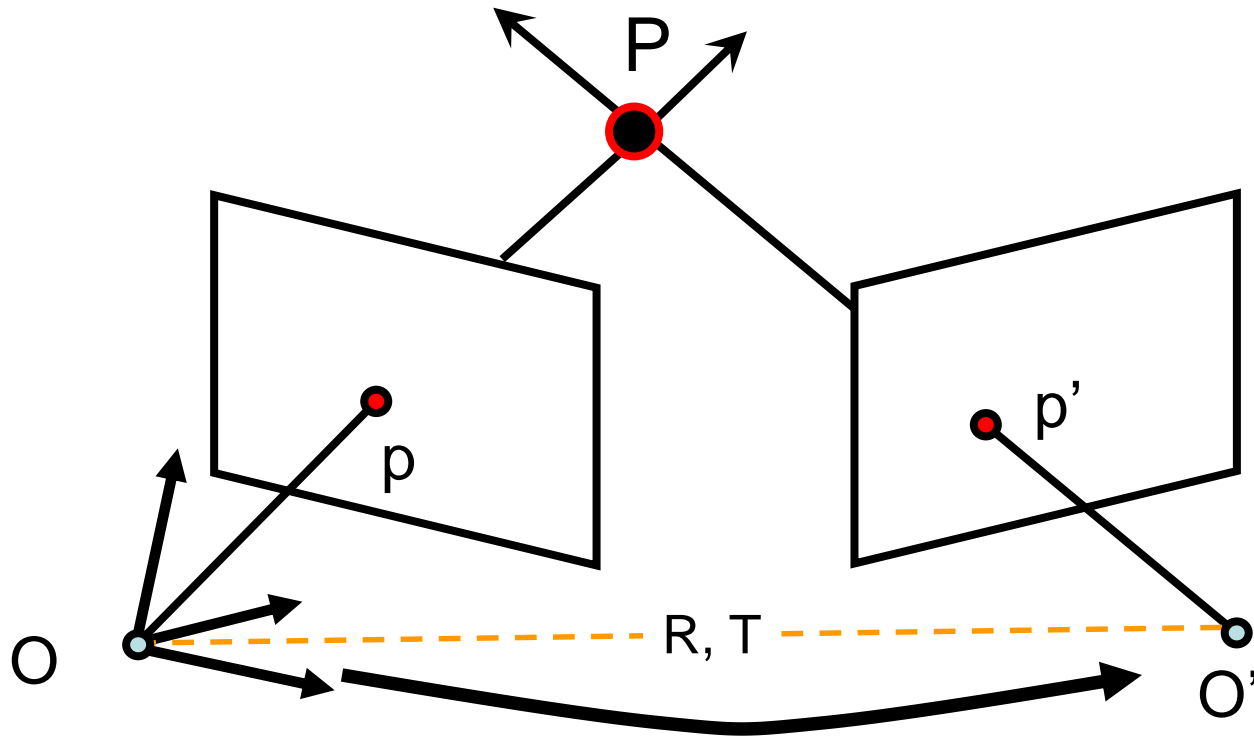

$$M = K \begin{bmatrix} I & 0 \end{bmatrix} \quad \boxed{K \text{ is unknown}} \quad M' = K \begin{bmatrix} R^T & -R^T T \end{bmatrix}$$

Epipolar Constraint

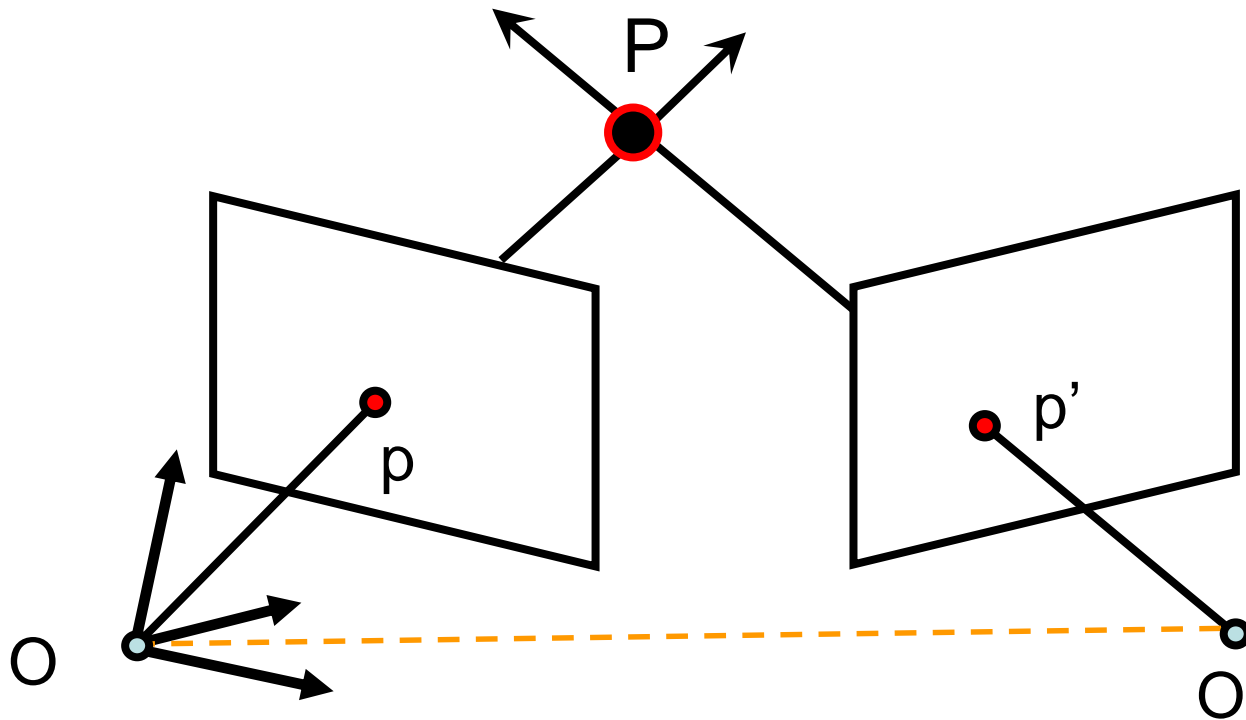

$$p^T F p' = 0$$

$$F = K^{-T} \cdot [T_{\times}] \cdot R K'^{-1}$$

F = Fundamental Matrix

(Faugeras and Luong, 1992)

Epipolar Constraint

$$p_1^T \cdot F p_2 = 0$$

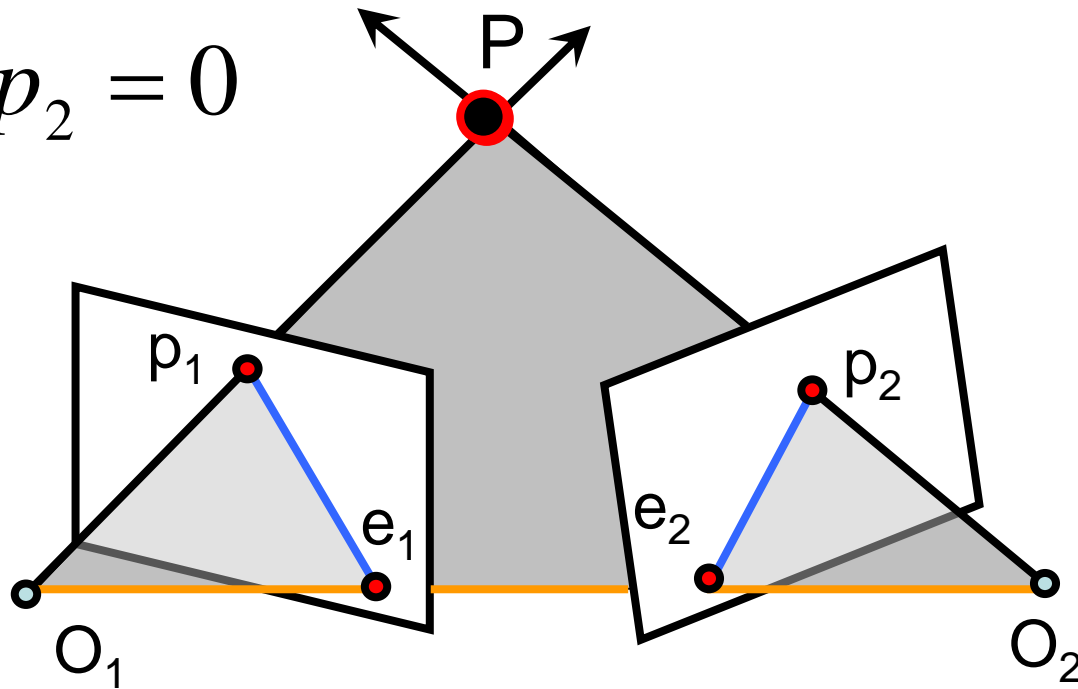

- $F p_2$ is the epipolar line associated with p_2 ($l_1 = F p_2$)
- $F^T p_1$ is the epipolar line associated with x_1 ($l_2 = F^T p_1$)
- $F e_2 = 0$ and $F^T e_1 = 0$
- F is 3x3 matrix; 7 DOF
- F is singular (rank two)

Why F is useful?

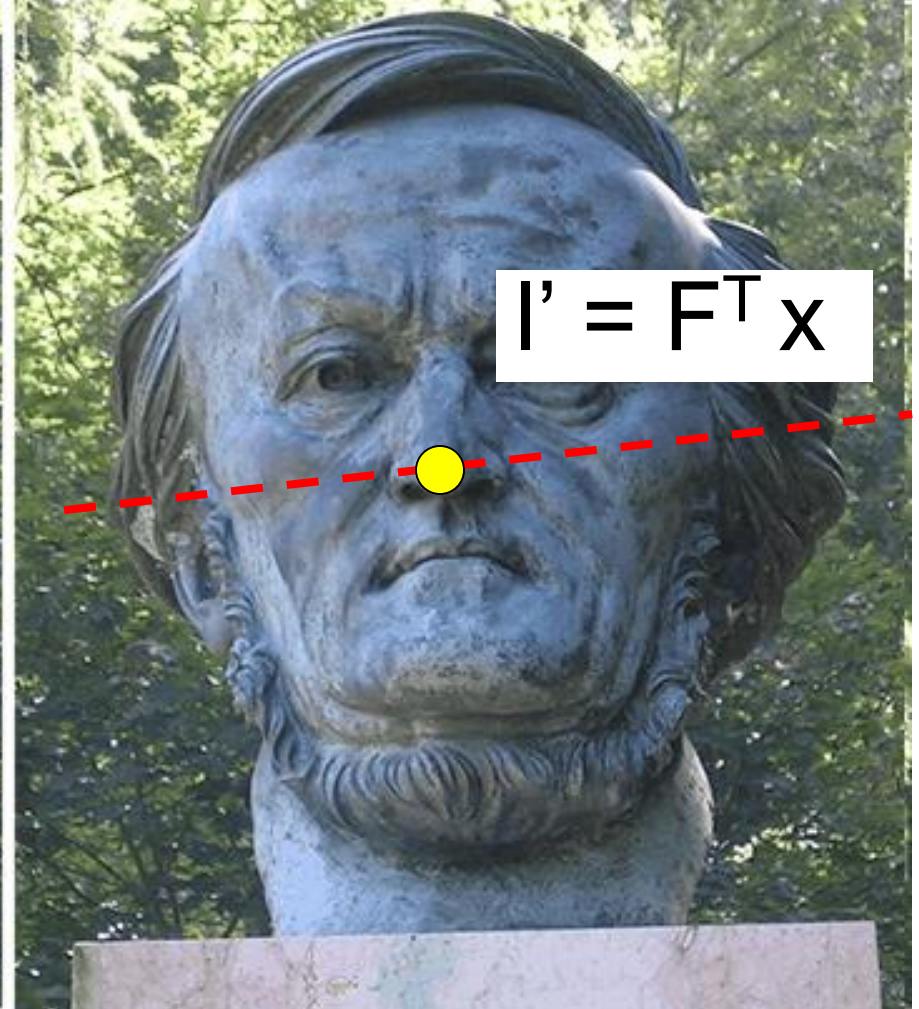
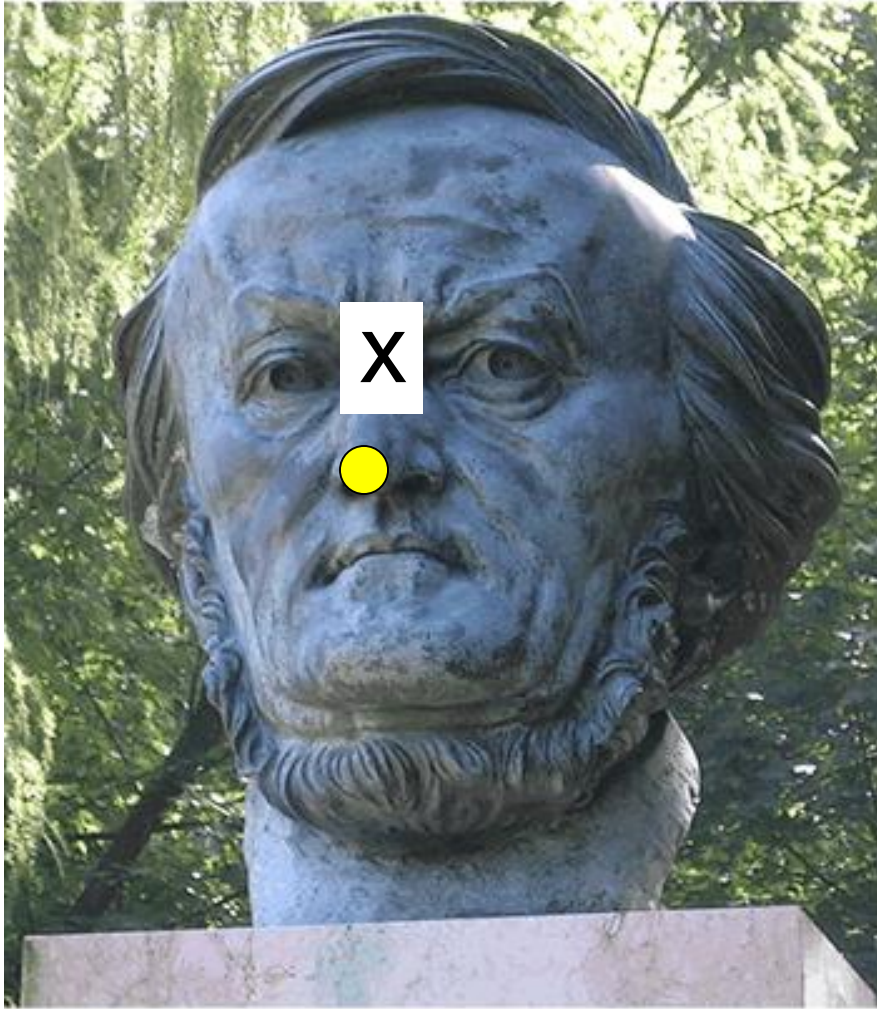

- Suppose F is known
- No additional information about the scene and camera is given
- Given a point on left image, how can I find the corresponding point on right image?

Why F is useful?

- F captures information about the epipolar geometry of 2 views + camera parameters
- **MORE IMPORTANTLY:** F gives constraints on how the scene changes under view point transformation (without reconstructing the scene!)
- Powerful tool in:
 - 3D reconstruction
 - Multi-view object/scene matching

Estimating F

The Eight-Point Algorithm

(Longuet-Higgins, 1981)

(Hartley, 1995)

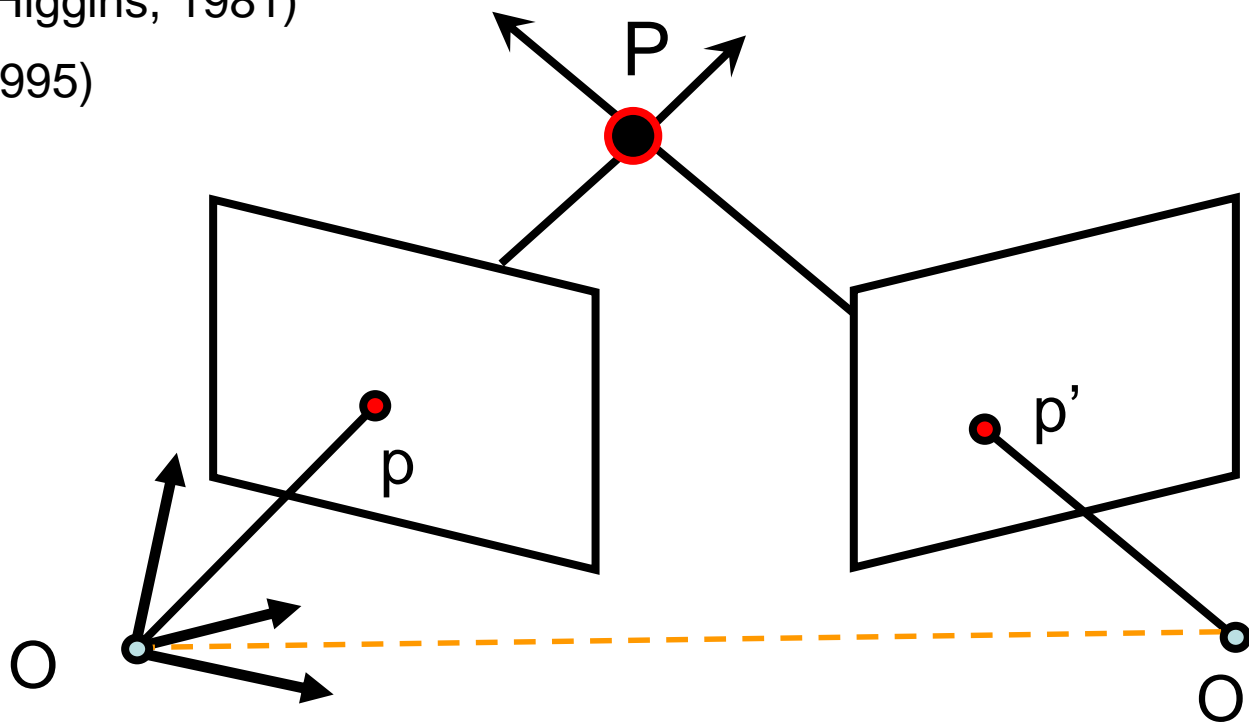

$$P \rightarrow p = \begin{bmatrix} u \\ v \\ 1 \end{bmatrix}$$

$$P \rightarrow p' = \begin{bmatrix} u' \\ v' \\ 1 \end{bmatrix}$$

$$p^T F p' = 0$$

Estimating F

$$\mathbf{p}^T \mathbf{F} \mathbf{p}' = 0 \quad \longrightarrow$$

$$(u, v, 1) \begin{pmatrix} F_{11} & F_{12} & F_{13} \\ F_{21} & F_{22} & F_{23} \\ F_{31} & F_{32} & F_{33} \end{pmatrix} \begin{pmatrix} u' \\ v' \\ 1 \end{pmatrix} = 0$$
$$\longrightarrow (uu', uv', u, vu', vv', v, u', v', 1) \begin{pmatrix} F_{11} \\ F_{12} \\ F_{13} \\ F_{21} \\ F_{22} \\ F_{23} \\ F_{31} \\ F_{32} \\ F_{33} \end{pmatrix} = 0$$

Let's take 8 corresponding points

Estimating F

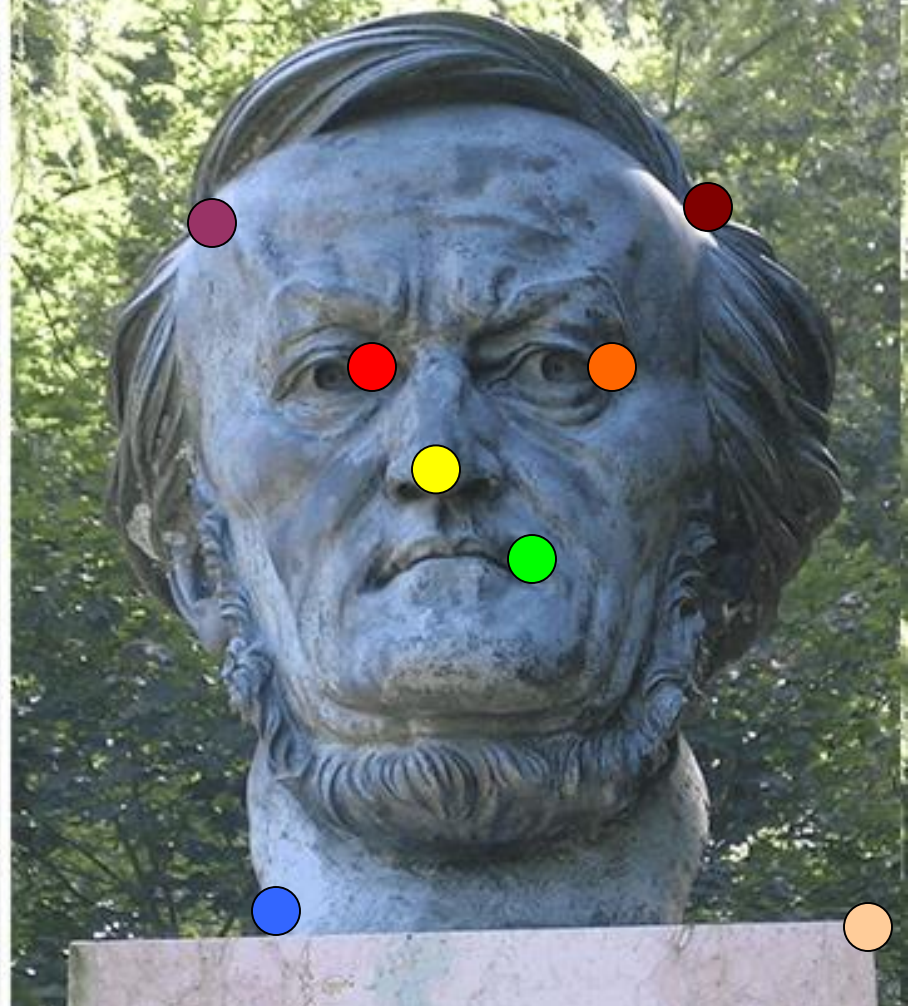
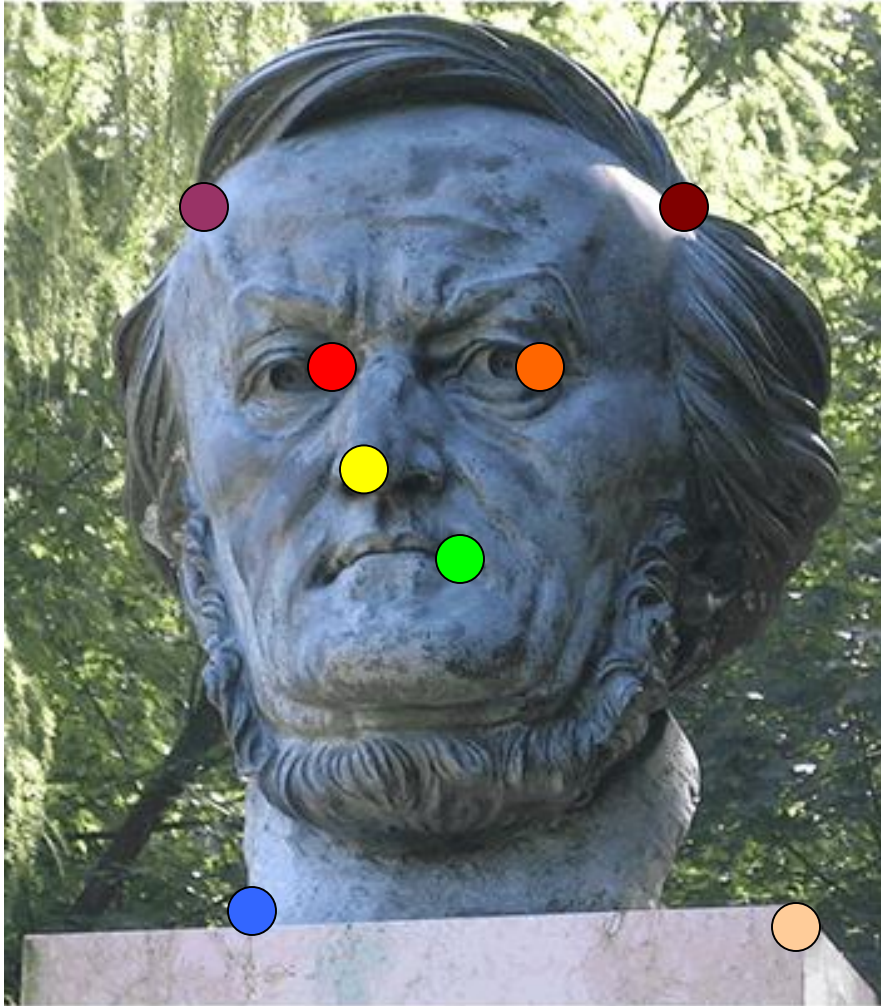

Estimating F

$$\mathbf{W} \begin{pmatrix} u_1 u'_1 & u_1 v'_1 & u_1 & v_1 u'_1 & v_1 v'_1 & v_1 & u'_1 & v'_1 & 1 \\ u_2 u'_2 & u_2 v'_2 & u_2 & v_2 u'_2 & v_2 v'_2 & v_2 & u'_2 & v'_2 & 1 \\ u_3 u'_3 & u_3 v'_3 & u_3 & v_3 u'_3 & v_3 v'_3 & v_3 & u'_3 & v'_3 & 1 \\ u_4 u'_4 & u_4 v'_4 & u_4 & v_4 u'_4 & v_4 v'_4 & v_4 & u'_4 & v'_4 & 1 \\ u_5 u'_5 & u_5 v'_5 & u_5 & v_5 u'_5 & v_5 v'_5 & v_5 & u'_5 & v'_5 & 1 \\ u_6 u'_6 & u_6 v'_6 & u_6 & v_6 u'_6 & v_6 v'_6 & v_6 & u'_6 & v'_6 & 1 \\ u_7 u'_7 & u_7 v'_7 & u_7 & v_7 u'_7 & v_7 v'_7 & v_7 & u'_7 & v'_7 & 1 \\ u_8 u'_8 & u_8 v'_8 & u_8 & v_8 u'_8 & v_8 v'_8 & v_8 & u'_8 & v'_8 & 1 \end{pmatrix} \begin{pmatrix} F_{11} \\ F_{12} \\ F_{13} \\ F_{21} \\ F_{22} \\ F_{23} \\ F_{31} \\ F_{32} \\ F_{33} \end{pmatrix} = \mathbf{0}$$

• Homogeneous system $\mathbf{W} \mathbf{f} = \mathbf{0}$

• Rank 8 \longrightarrow A non-zero solution exists (unique)

• If $N > 8$ \longrightarrow Lsq. solution by SVD! $\longrightarrow \hat{\mathbf{F}}$

$$\|\mathbf{f}\| = 1$$

$$\hat{F} \text{ satisfies: } \mathbf{p}^T \hat{F} \mathbf{p}' = 0$$

and estimated \hat{F} may have full rank ($\det(\hat{F}) \neq 0$)

But remember: fundamental matrix is Rank2

Find F that minimizes $\|F - \hat{F}\| = 0$

Frobenius norm (*)

Subject to $\det(F)=0$

SVD (again!) can be used to solve this problem

(*) Sqrt root of the sum of squares of all entries

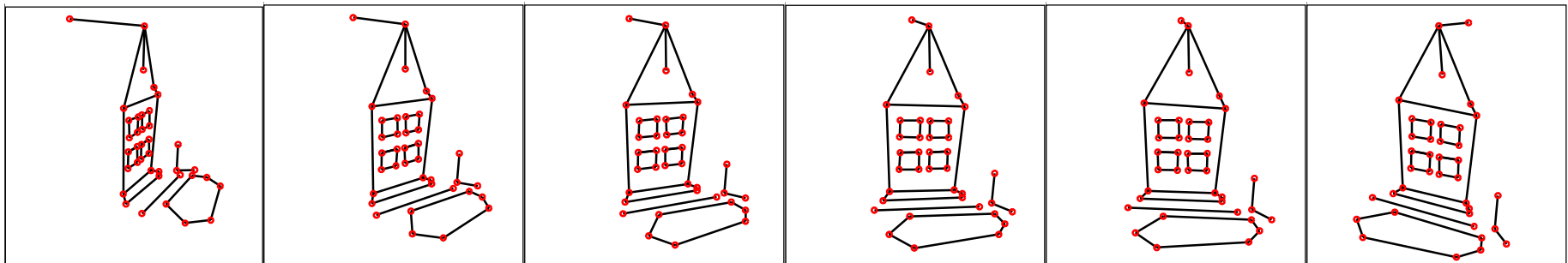
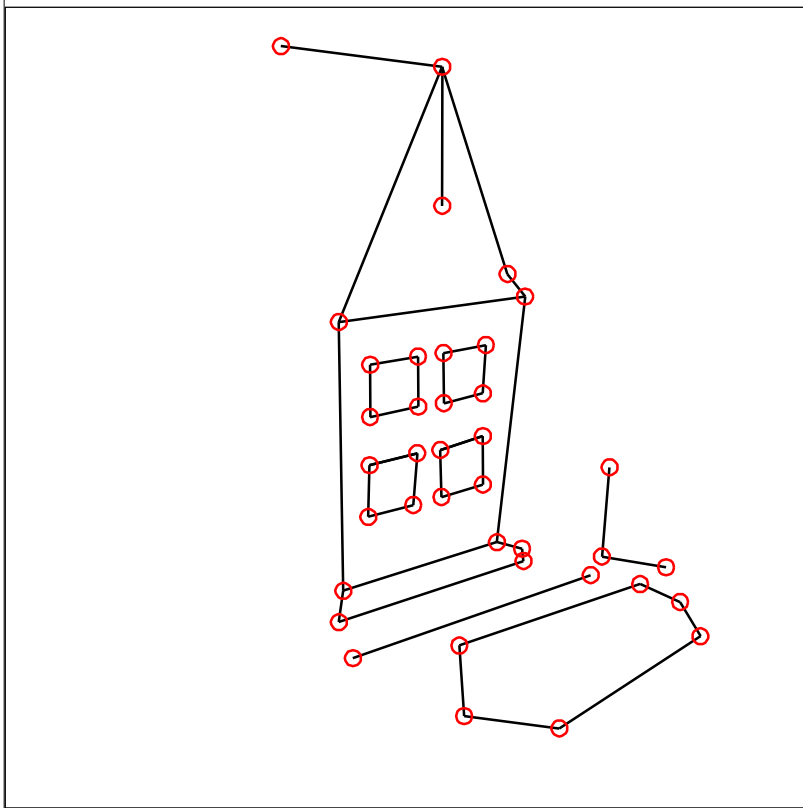

Data courtesy of R. Mohr and B. Boufama.

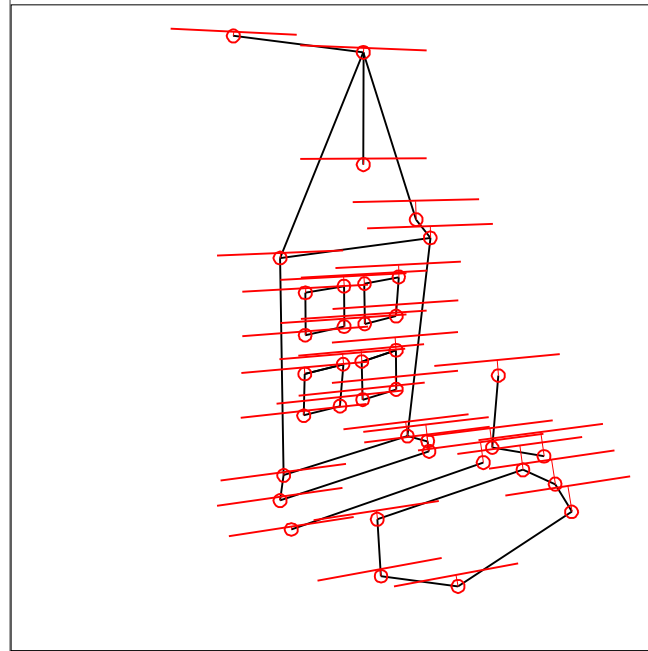
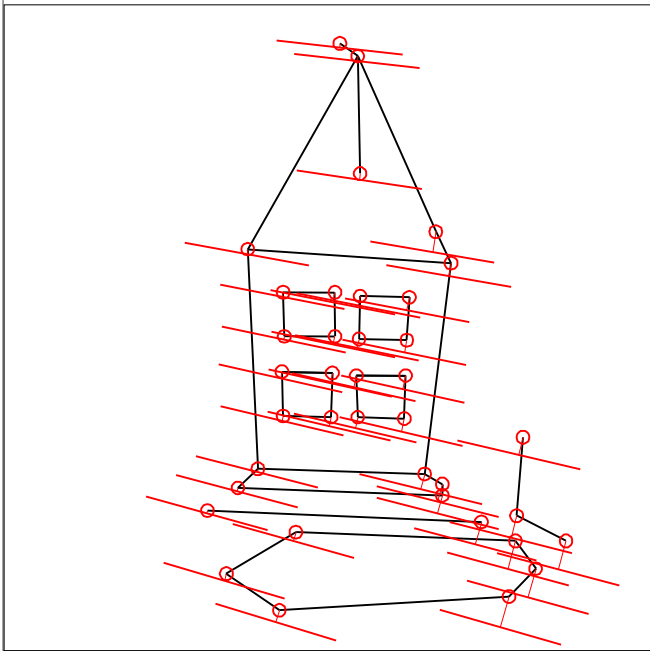

Mean errors:
10.0pixel
9.1pixel

Problems with the 8-Point Algorithm

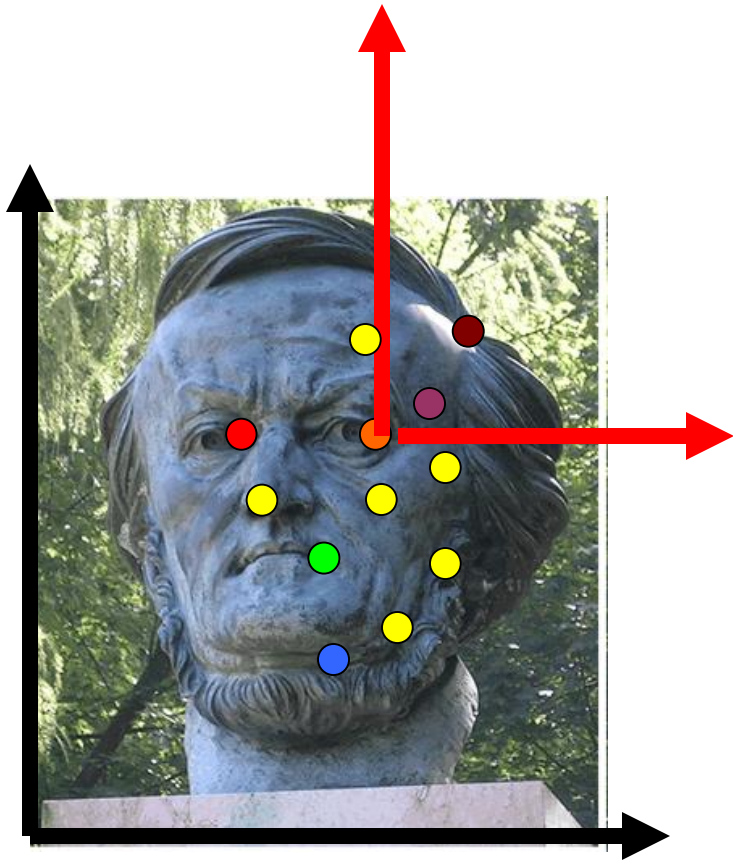

$$\mathbf{W} \mathbf{f} = \mathbf{0},$$

$$\|\mathbf{f}\| = 1$$

Lsq solution
by SVD



\mathbf{F}

- Recall the structure of \mathbf{W} :
 - do we see any potential (numerical) issue?

Problems with the 8-Point Algorithm

$$\mathbf{W} \mathbf{f} = \mathbf{0}$$

$$\mathbf{W} = \begin{pmatrix} u_1 u'_1 & u_1 v'_1 & u_1 & v_1 u'_1 & v_1 v'_1 & v_1 & u'_1 & v'_1 & 1 \\ u_2 u'_2 & u_2 v'_2 & u_2 & v_2 u'_2 & v_2 v'_2 & v_2 & u'_2 & v'_2 & 1 \\ u_3 u'_3 & u_3 v'_3 & u_3 & v_3 u'_3 & v_3 v'_3 & v_3 & u'_3 & v'_3 & 1 \\ u_4 u'_4 & u_4 v'_4 & u_4 & v_4 u'_4 & v_4 v'_4 & v_4 & u'_4 & v'_4 & 1 \\ u_5 u'_5 & u_5 v'_5 & u_5 & v_5 u'_5 & v_5 v'_5 & v_5 & u'_5 & v'_5 & 1 \\ u_6 u'_6 & u_6 v'_6 & u_6 & v_6 u'_6 & v_6 v'_6 & v_6 & u'_6 & v'_6 & 1 \\ u_7 u'_7 & u_7 v'_7 & u_7 & v_7 u'_7 & v_7 v'_7 & v_7 & u'_7 & v'_7 & 1 \\ u_8 u'_8 & u_8 v'_8 & u_8 & v_8 u'_8 & v_8 v'_8 & v_8 & u'_8 & v'_8 & 1 \end{pmatrix} \begin{pmatrix} F_{11} \\ F_{12} \\ F_{13} \\ F_{21} \\ F_{22} \\ F_{23} \\ F_{31} \\ F_{32} \\ F_{33} \end{pmatrix} = \mathbf{0}$$

- Highly un-balanced (not well conditioned)
- Values of W must have similar magnitude
- This creates problems during the SVD decomposition

Normalization

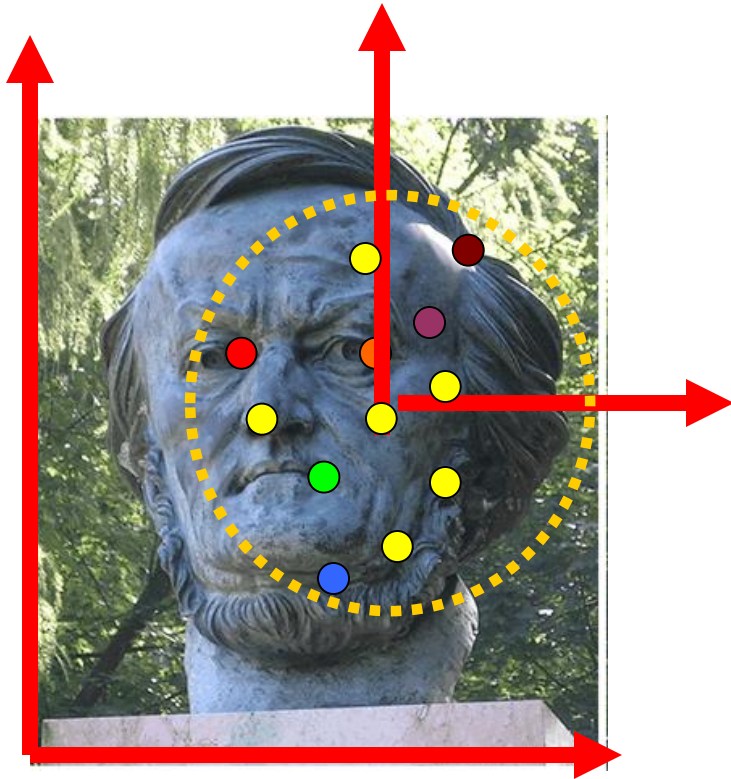

IDEA: Transform image coordinate such that the matrix \mathbf{W} become better conditioned (**pre-conditioning**)

Apply following transformation T :
(translation and scaling)

- Origin = centroid of image points
- Mean square distance of the data points from origin is 2 pixels

$$q_i = T p_i \quad q'_i = T' p'_i \quad (\text{normalization})$$

The Normalized Eight-Point Algorithm

0. Compute T and T'

1. Normalize coordinates:

$$q_i = T p_i \quad q'_i = T' p'_i$$

2. Use the eight-point algorithm to compute F'_q from the points q_i and q'_i .

1. Enforce the rank-2 constraint. $\rightarrow F_q$ $\left\{ \begin{array}{l} q^T F_q q' = 0 \\ \det(F_q) = 0 \end{array} \right.$

2. De-normalize F_q : $F = T^T F_q T'$

Without transformation

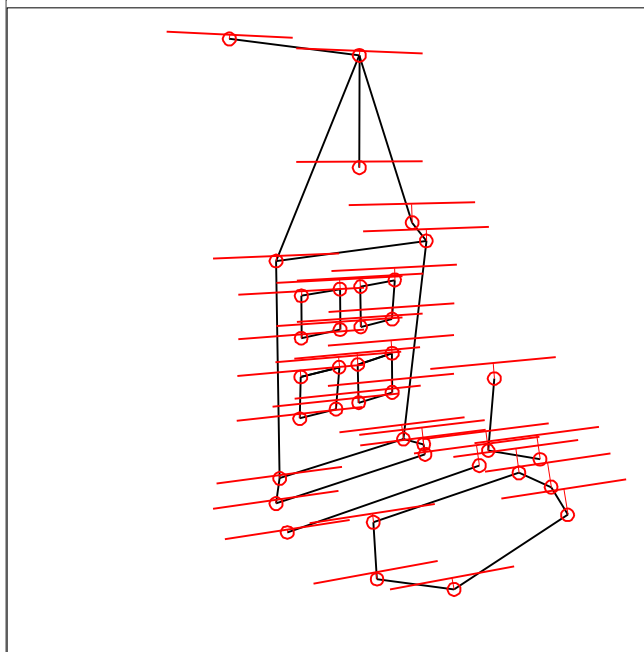
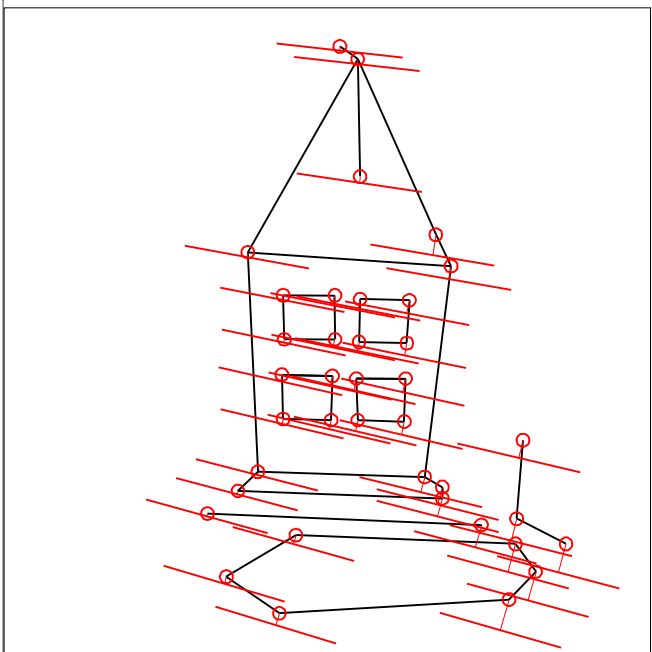

Mean errors:
10.0pixel
9.1pixel

With transformation

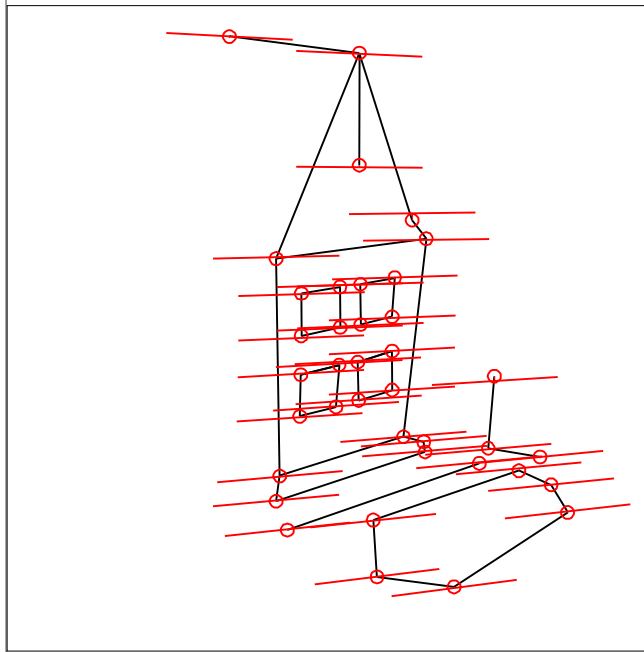
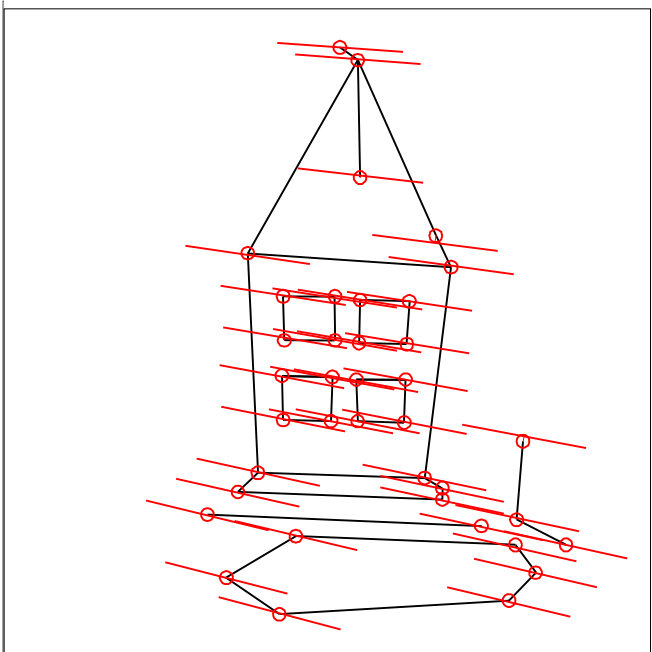

Mean errors:
1.0pixel
0.9pixel

Same issue for the DLT algorithm

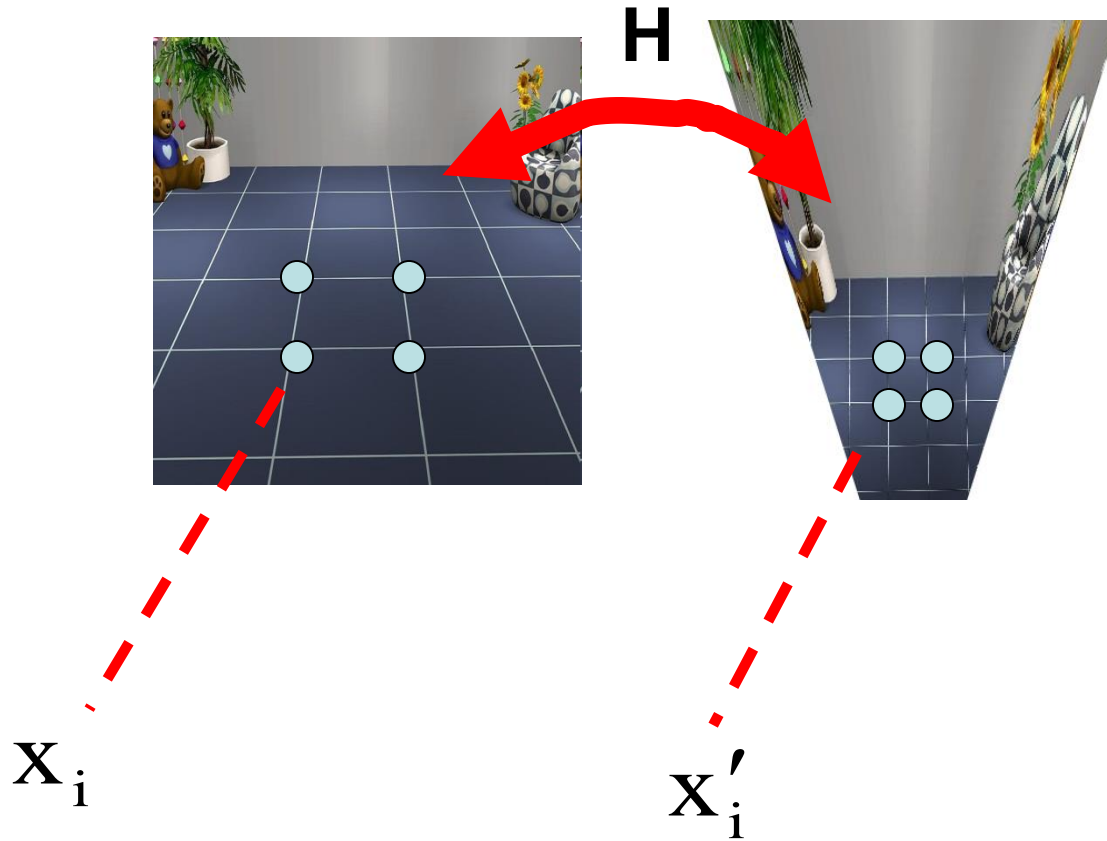

$$x'_i = H x_i$$

[Section 4.4 in AZ]

Lecture 5

Epipolar Geometry

- Why is stereo useful?
- Epipolar constraints
- Essential and fundamental matrix
- Estimating F
- Examples

Reading: [AZ] Chapter: 4 “Estimation – 2D perspective transformations”
Chapter: 9 “Epipolar Geometry and the Fundamental Matrix Transformation”
Chapter: 11 “Computation of the Fundamental Matrix F ”
[FP] Chapters: 10 “The geometry of multiple views”



Example: Parallel image planes

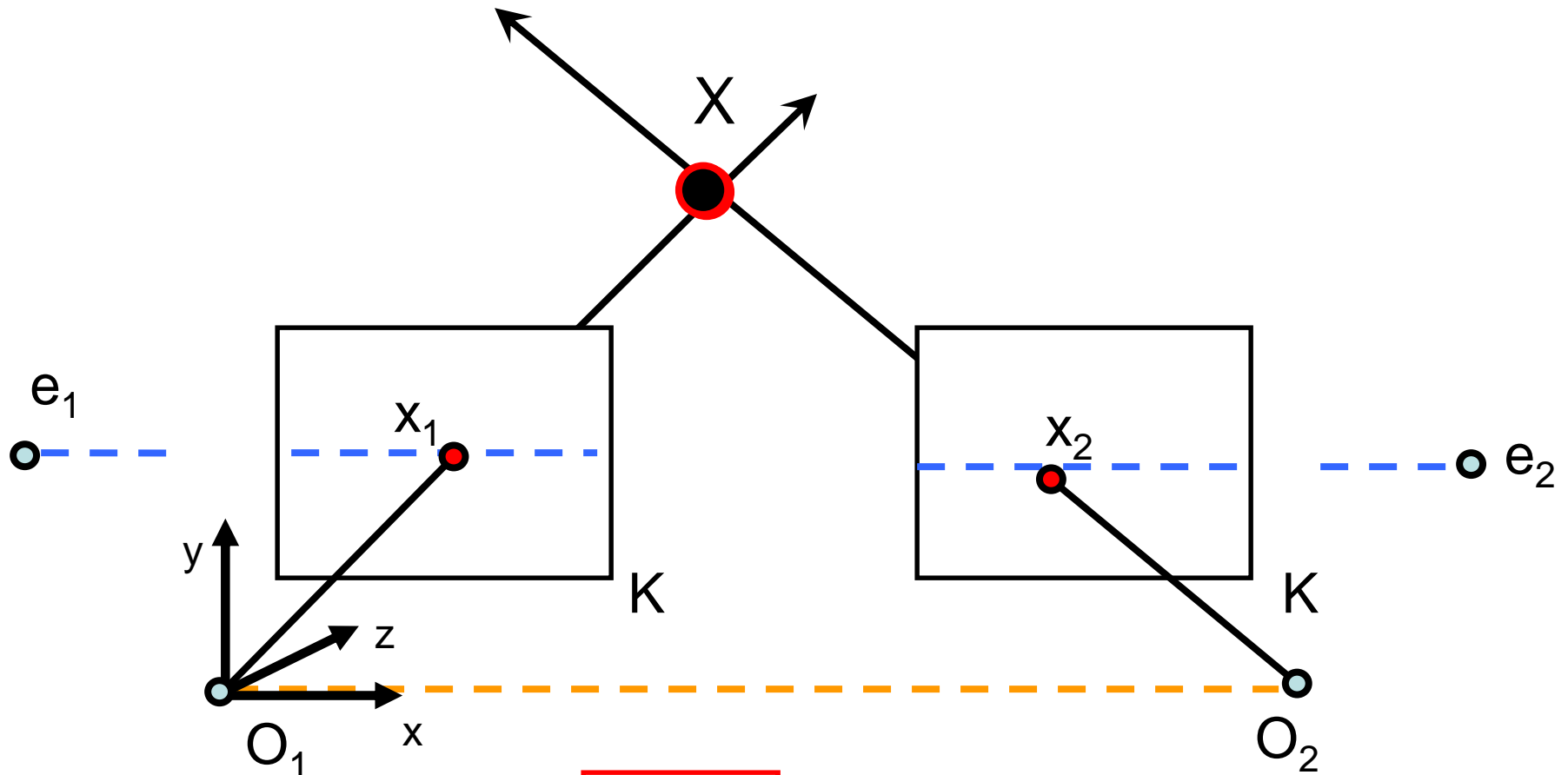

$$E = ?$$

Hint :

$$R = I \quad t = (T, 0, 0)$$

$K_1 = K_2 = \text{known}$

x parallel to O_1O_2

Essential matrix for parallel images

$$\mathbf{E} = [\mathbf{T}_\times] \cdot \mathbf{R}$$

$$\mathbf{E} = \begin{bmatrix} 0 & -T_z & T_y \\ T_z & 0 & -T_x \\ -T_y & T_x & 0 \end{bmatrix} \mathbf{I} = \begin{bmatrix} 0 & 0 & 0 \\ 0 & 0 & -T \\ 0 & T & 0 \end{bmatrix}$$

$$\mathbf{T} = [T \ 0 \ 0]$$

$$\mathbf{R} = \mathbf{I}$$

Example: Parallel image planes

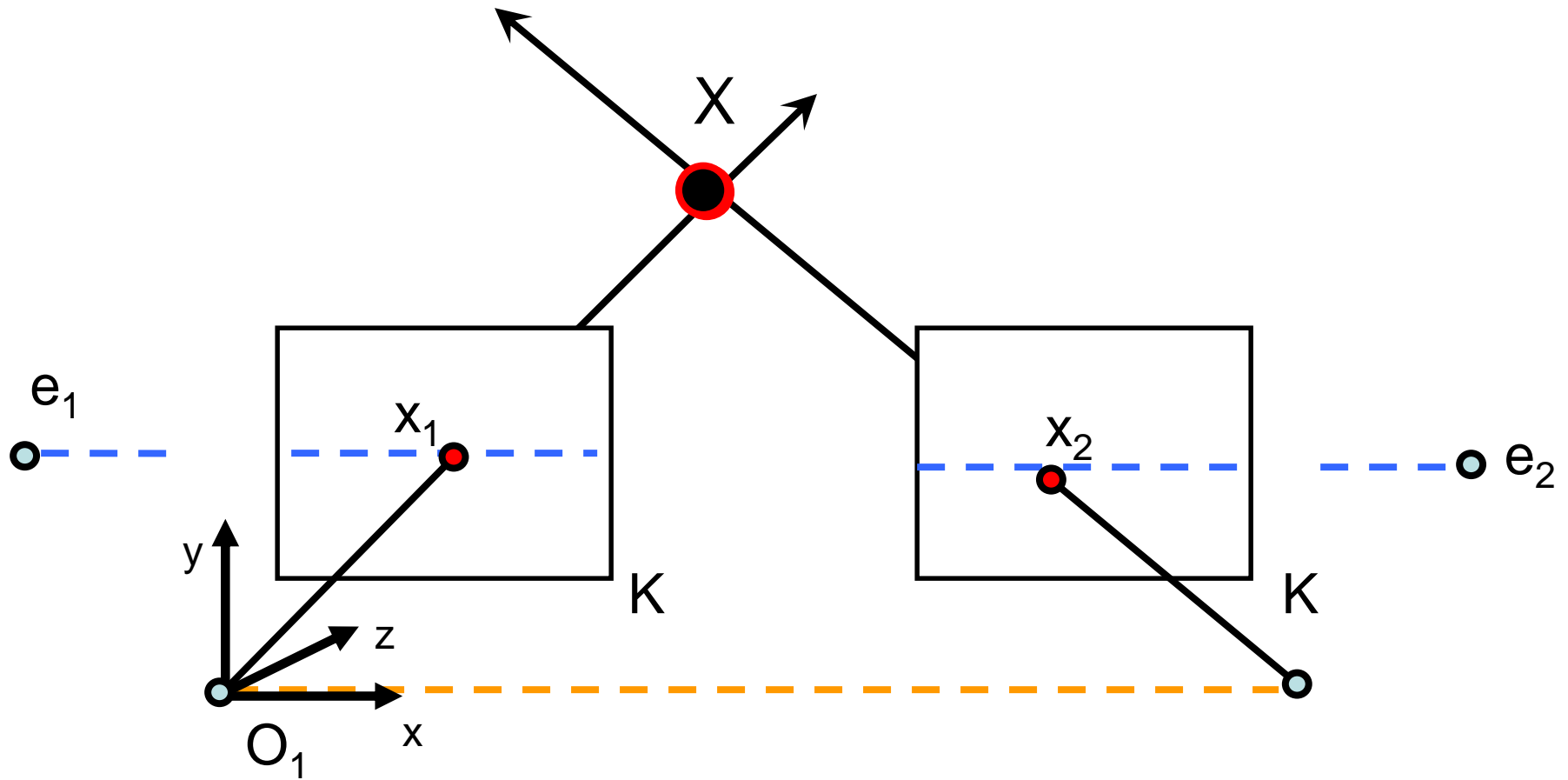

What are the directions of epipolar lines?

$$l_1 = E \mathbf{x}_2 = \begin{bmatrix} 0 & 0 & 0 \\ 0 & 0 & -T \\ 0 & T & 0 \end{bmatrix} \mathbf{x}_2 = \begin{bmatrix} 0 \\ -T x_3 \\ T x_2 \end{bmatrix} \quad \text{horizontal!}$$

Example: Parallel image planes

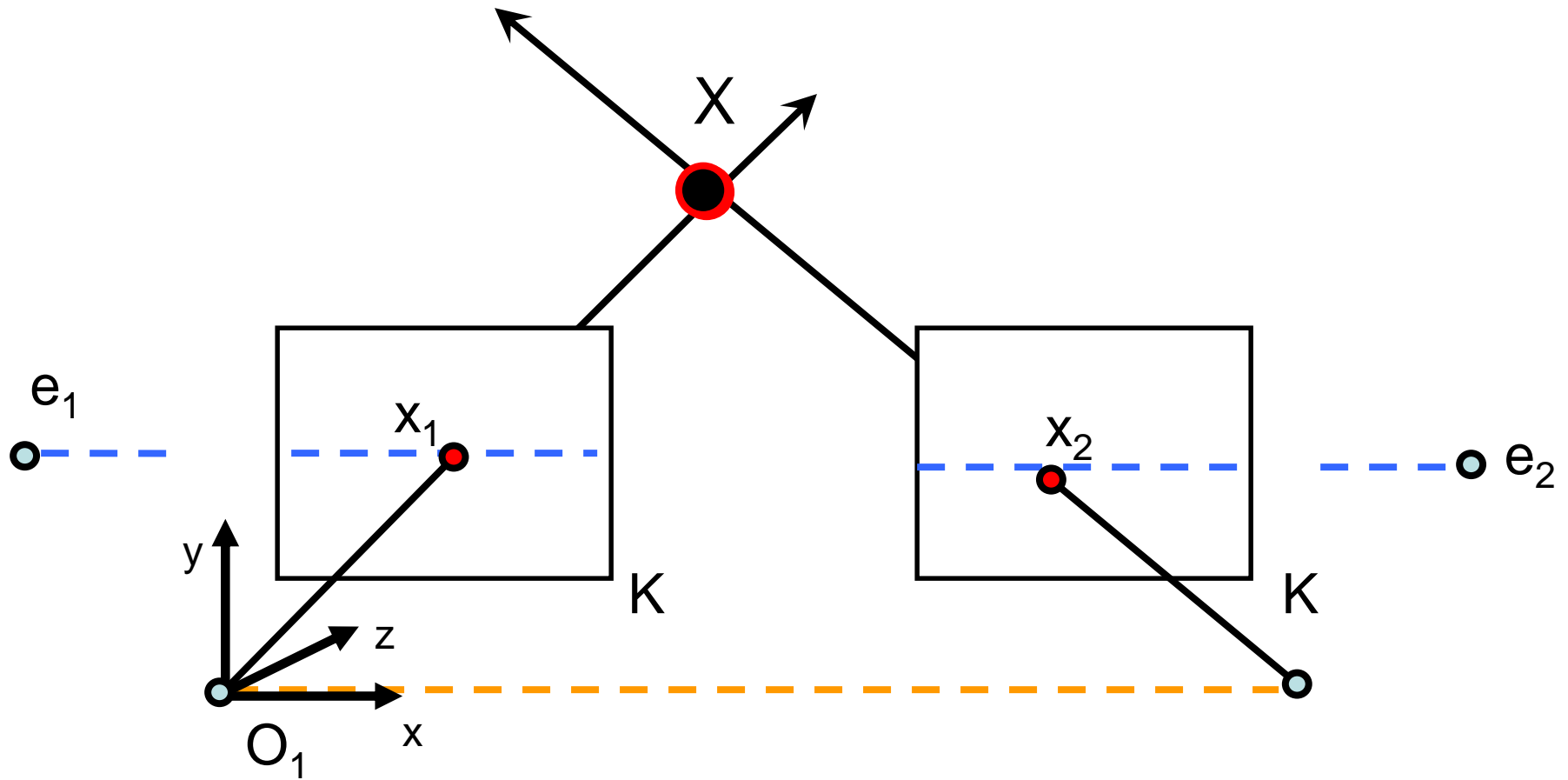

How are x_1 and x_2 related?

$$x_1^T \cdot E x_2 = 0$$

Example: Parallel image planes

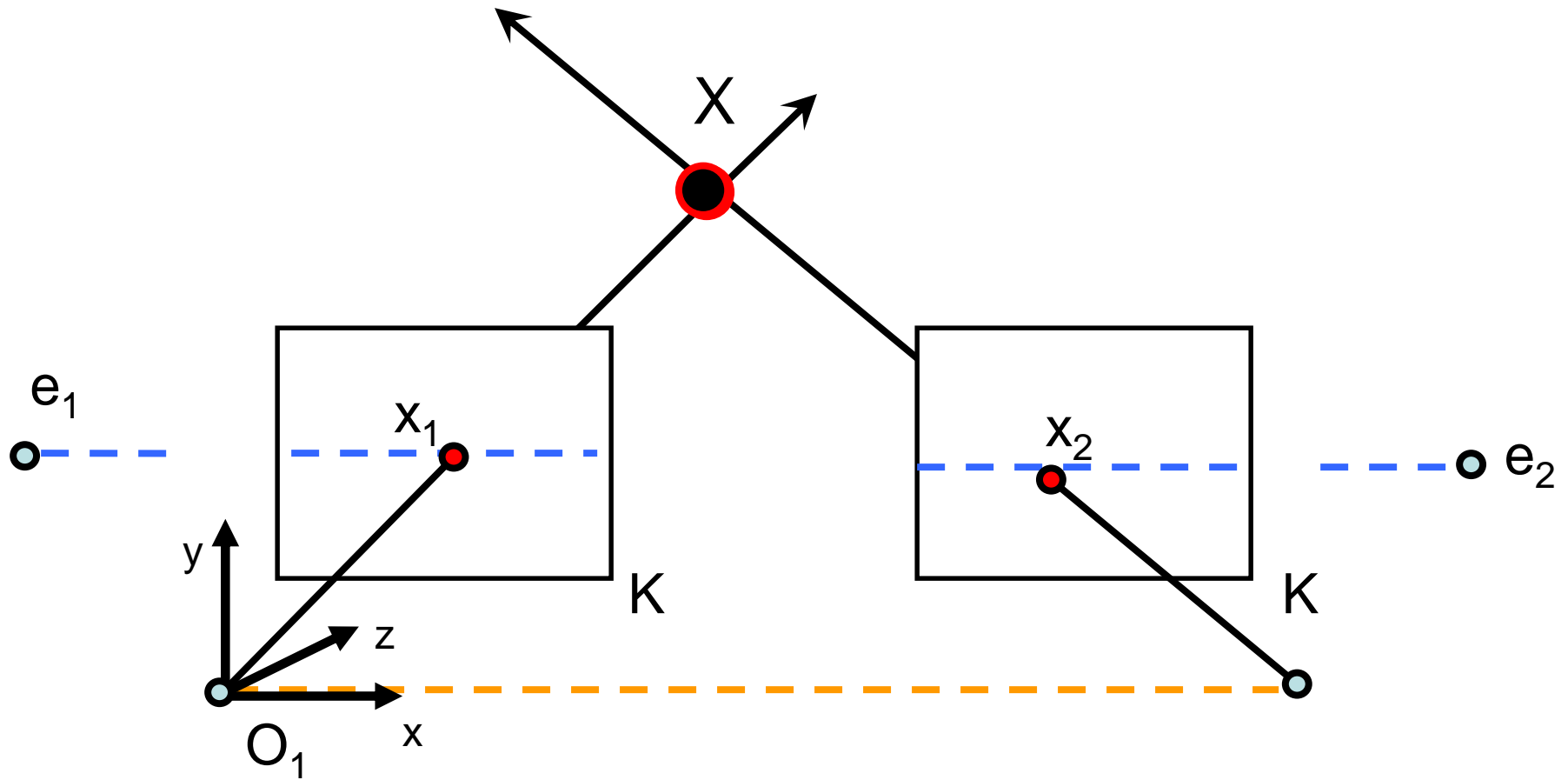

How are x_1 and x_2 related?

$$\Rightarrow (u \quad v \quad 1) \begin{bmatrix} 0 & 0 & 0 \\ 0 & 0 & -T \\ 0 & T & 0 \end{bmatrix} \begin{pmatrix} u' \\ v' \\ 1 \end{pmatrix} = 0 \Rightarrow (u \quad v \quad 1) \begin{pmatrix} 0 \\ -T \\ Tv' \end{pmatrix} = 0 \Rightarrow Tv = Tv'$$

Example: Parallel image planes

For details on how to rectify two views see CS131A Lecture 9

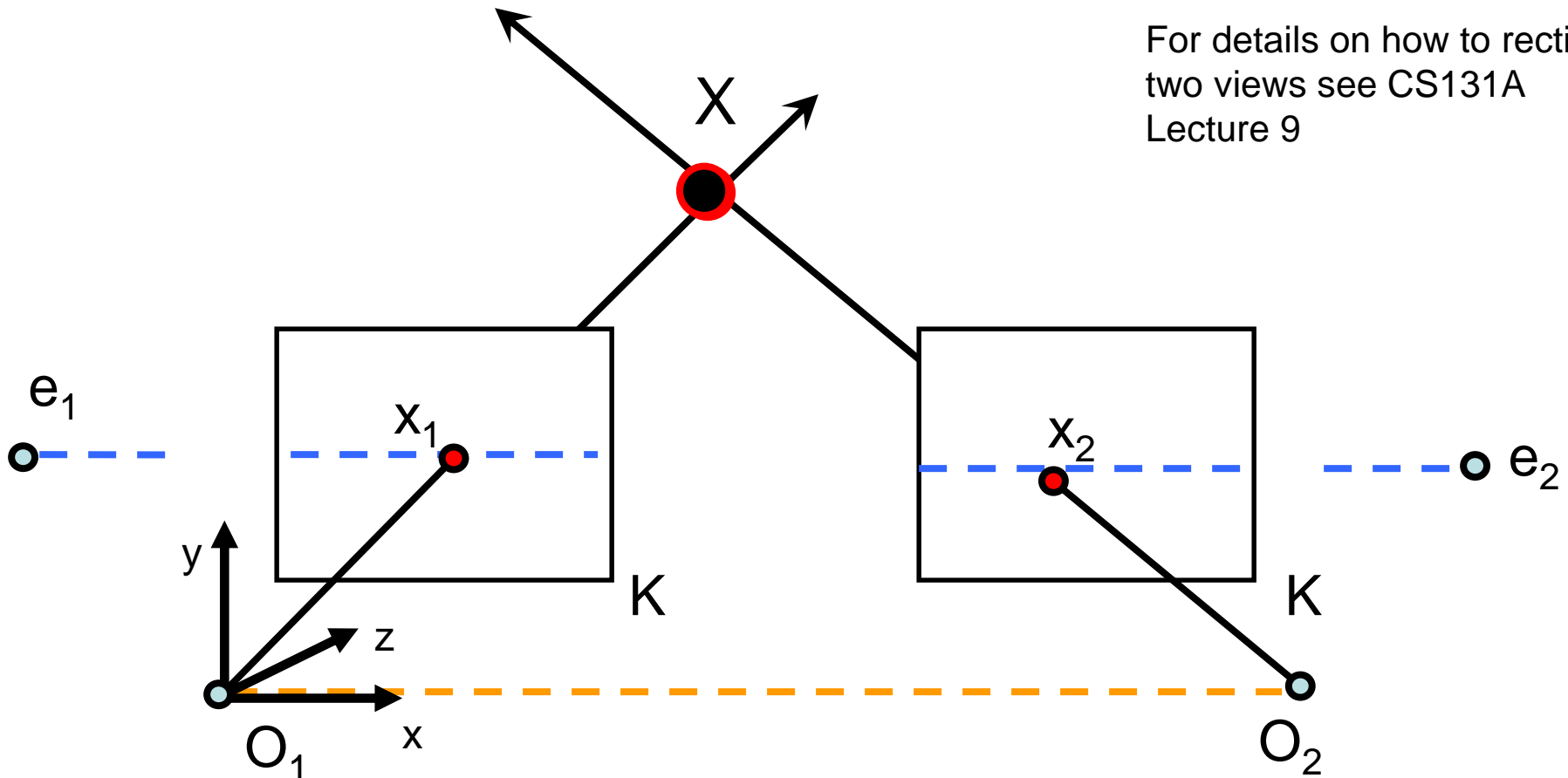

Rectification: making two images “parallel”

- Why it is useful?
- Epipolar constraint $\rightarrow y = y'$
 - New views can be synthesized by linear interpolation

Next lecture:

Stereo systems and affine SFM